

Digital Legacy Lab Frequently Asked Questions

What can be digitized

Each Geauga County Public Library branch has a fully-equipped Digital Legacy Lab. Media formats that can be digitized include:



Audio Formats	
Vinyl (33 1/3 & 45rpm)	
Audio Cassettes	
CDs	
Live audio	

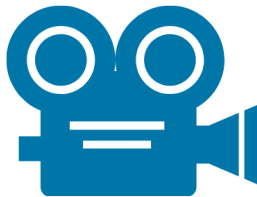

Video Formats	
8mm film	DVDs
Super8 film	Mini DVDs
8mm cassettes	Mini DV tapes
Hi8 film	VHS and VHS-C



Image and Document Formats
Documents and Photographs (up to 8.5"x11")
50mm slides (135, 126, & 110)
Film and photo negatives (135, 126, & 110)
Medium Format Film (up to 2.36"x8.66")
4" x 5" Film
Large format film (up to 8"x10")

Available by request: 78rpm vinyl records; 8mm and Super8 negatives

Available Software:

The Digital Legacy Lab includes editing software to assist patrons with digitization and other personal design projects. Available software includes:

Image Editing

- Adobe Photoshop
- Adobe Lightroom
- GIMP
- Inkscape
- Krita

Video Editing

- Adobe After Effects
- Blender
- OpenShot

Audio Editing

- Audacity
- Adobe Audition

Also included from the Adobe Creative Cloud: Illustrator, InDesign, Dreamweaver, Animate, etc.

Frequently Asked Questions:

Is training mandatory?

No. All you need to do is sign the Digital Legacy Lab User Agreement when you first come in to use the lab. In-person orientation is available at least once a month if you would like more information, but it is not mandatory. The orientation is also available on the Digital Legacy Lab computer or online at GeaugaLibrary.net/DLL for reference.

How do I schedule a session in the Digital Legacy Lab?

Call or talk in-person to the Reference Desk at any Geauga County Public Library Branch, or schedule online at GeaugaLibrary.net/DLL. Sessions are automatically two (2) hours long, but you can choose any start and end time within library hours (the Digital Legacy Lab closes 30 minutes prior to the library).

Where can I access the tutorials?

Written and video tutorials are available on the Digital Legacy Lab computers. The video tutorials are available on the Geauga County Public Library website. Physical copies of the written tutorials are in a binder with each Digital Legacy Lab for reference. You can also download the written tutorials when you register online for the Digital Legacy Lab Orientation, or from the Geauga County Public Library website.

To access the video tutorials and digital copies of the written tutorials, please visit GeaugaLibrary.net/DLL.

Is my information safe in the Digital Legacy Lab?

Geauga County Public Library takes privacy very seriously. The Digital Legacy Lab computers wipe all data at the end of every day. This is an automatic process, and the library recommends saving periodically throughout your session to ensure your files are not deleted before you can save them to your USB drive. More information on GCPL's public computer and internet policies can be found in Operating Policy 696 Internet Use by The Public.

The 8mm film converter and the Kodak Slide N Scan slide and film converter are not automatically wiped clean after use. You must manually delete these files from the device as explained in the written and video tutorials. It is mentioned in the User Agreement that Geauga County Public Library is not held accountable for data left on the Digital Legacy Lab devices, but we try to protect your privacy as much as possible and will immediately delete files if found on the converters.

As an added precaution, you are always welcome to delete any files yourself before logging off the Digital Legacy Lab computer.

I would like hands-on training in the Digital Legacy Lab.

The Digital Legacy Lab is designed to be self-service. Written tutorials are available on the desktop computer or in the Digital Legacy Lab binder, and video tutorials are available on the desktop or on the Geauga County Public Library website.

For additional support, you may sign up for Consultation Hours with the Digitization Specialist. Consultation Hours occur at least once a month at each branch in two 2-hour sessions. To schedule a one-on-one appointment, talk to the library Reference staff, or visit the Digital Legacy Lab page at GeaugaLibrary.net/DLL. The Digitization Specialist will not physically handle or digitize any of your media.

Library branch staff will not assist with any digitization. Branch staff may assist with troubleshooting issues only. An assistant of your choosing (such as a family member or friend) must also sign the Digital Legacy Lab Agreement before they can assist.

May I have someone in the Digital Legacy Lab with me even if they have not taken signed the agreement?

Yes, you may have a guest with you while digitizing. If your guest has not signed the User Agreement, they may not touch any devices in the Digital Legacy Lab. We recommend only one guest as most rooms where the Digital Legacy Lab is located are small.

I don't know how to use the editing software on the Digital Legacy Lab.

The Digital Legacy Lab includes the entire Adobe Creative Cloud software for editing and finalizing all your digitization projects. This includes Photoshop Photo Editor, Lightroom Bulk Photo Editor, Illustrator Image Editor, and Audition Audio Editor. Also included are open-source editing software such as OpenShot, GIMP, Krita, Inkscape, Blender, and Audacity, which you can also download at home on your personal computer.

We encourage patrons to explore the software themselves. To learn more, you can either watch videos on YouTube or access LinkedIn Learning, a free database of courses available through Geauga County Public Library on the library's website. Some courses are hours long, so the library recommends accessing LinkedIn Learning before coming in to use the Digital Legacy Lab. The Adobe Creative Cloud software also includes hands-on training modules under "Learn".

Library staff are not expected to know how to use the editing software.

Can the Digital Legacy Lab digitize 8-track tapes, Betamax, or Reel to Reel?

Not currently.

Does the Digital Legacy Lab accept requests for other media formats to digitize?

We cannot promise that we will be able to acquire additional equipment, but we are always interested in knowing if there are additional formats you would like the library to consider. Email your suggestions to the Digital Legacy Lab at DLL@GeaugaLibrary.net.

Can I digitize any other video cassette tapes from a camcorder other than VHS-C, Hi8, 8mm, or MiniDV?

Yes, but only if you have the camcorder you used to record the tapes and it still works. You use the VHS to DVD converter and plug it into the camcorder. It will work the same as the VCR/DVD player. The library only has adapters for VHS-C, and camcorders for Hi8, 8mm, and MiniDV. We do not provide any other cassette camcorders currently.

My USB drive says it is corrupted after I have used the Digital Legacy Lab and then tried to access my files at home. What does this mean?

This may happen if the USB drive is older or if switching between an Apple computer and the Digital Legacy Lab computer. The Digital Legacy Lab computers are Personal Computers (PCs) and use the Windows operating system which does not always transfer well to the Apple operating system (iOS). Please be sure to bring PC-compatible storage drives. If you have any questions about compatibility, please contact the Digitization Specialist or sign up for Consultation Hours with the Digitization Specialist.

The file will not save to the USB drive. It says the file is too big, but the USB drive has enough space.

Depending on the USB drive, the flash memory (how it transfers data on to the USB drive) may have a maximum limit which is less than the amount of storage it contains. For example, it might be an 8 GB USB drive, but can only transfer 2 GB of data at a time. It is like putting your items in a moving truck: only so much can be moved at once. The file must be put in a zip folder and then saved to the USB drive where it can then be extracted. This information is available in the Digital Legacy Lab binder for reference.

Can I make copies of DVDs?

Yes, this is possible with the Honestech software for the VHS tape converter. You can record the DVD by playing it and watching it with Honestech recording. You can then burn the new digital copy to another DVD or save it to a USB drive.

As stated in the user agreement, patrons must follow all applicable intellectual property laws, including all copyright laws. GCPL reserves the right to halt, delete or disallow the creation of items that violate Library policy.

Can I use more than one device at a time?

Yes, with some restrictions. You cannot digitize two different audio media at the same time (e.g., recording cassette tapes and a vinyl record at the same time). Otherwise, any combination of devices can be digitizing simultaneously, so long as they do not use the same software at the same time (e.g., Hi8 cassette tapes and VHS tapes both require Honestech).

The 8mm/Super8 film converter and the slide scanner save their files directly on the device, so they do not affect the computer. If using the Epson FastFoto scanner and another device, scan batches of 30 photographs or less at a time as larger batches might freeze the computer.

Why does the Digital Legacy Lab recommend saving to USB drives?

A USB drive is recommended for storing your digitization projects. USB drives can hold a great amount of memory, up to 1TB or more. For comparison, CDs only hold 0.7 GB and DVDs hold 4.5 GB, so USB drives can hold more information and files. 8 GB or more of memory on the USB drive is recommended.

Additionally, USB drives are more accessible. Not everyone has an optical drive (CD/DVD reader) on their devices and while DVDs are great for archival purposes, they are becoming obsolete. USB drives will be easier to migrate in the future as CD/DVD drives become rarer.

Can I save my files to a CD or DVD?

Yes. Refer to the Digital Legacy Lab Written Tutorial for how to save files on a DVD.

How long does it take to digitize 8mm film?

It takes **at least 5x longer** to digitize 8mm film than to watch it. For example, if it is a 5-minute video, it will take at least 25 minutes to digitize. If you do not know how long the 8mm video is, try to get through as far as you can. You can splice videos back together using Adobe Premiere Video Editing software on the Digital Legacy Lab computer.

You may also want to schedule your appointment in the Digital Legacy Lab in the morning or for a longer session, to give yourself as much time as possible in the Lab.

How long does it take to digitize a cassette tape, vinyl record, or VHS tape?

Anything that involves sound must be digitized in real time as the device must record the sound as it plays. For example, if you are digitizing a 2-hour VHS movie, it will take 2 hours. Trying to speed up the process will distort the sound.

How can I record an 8-hour VHS tape in only 2 hours?

Some at-home VHS tapes may have 8-10 hours of video. Usually, the hours are split between events, and you can use those breaks to make separate digital files of each section. In the long run, this may make saving the files easier as shorter files save to the USB drive faster and you can name them specifically for that one video rather than a generic title for the entire 8 hours (ex: VHS tape was marked 1993, but you could have specific videos like Trevor's 1st birthday 1993, Pumpkin Festival 1993, 4th of July 1993 which all are on the VHS Tape).

If it is a wedding video of the whole day or another type of video you want to keep it as is, you can edit the video back together using OpenShot video editing software. Since you must manually rewind the VHS tape, you can end your session after two hours, leave the VHS tape where you left off, and continue the next time you are available. You must save your files before you log off the computer as the Digital Legacy Lab deletes all files after your session has ended.

What if I have a photograph or document that is larger than 8.5" x 11"?

If the image is up to 8.5" x 50", you can scan it with the Epson FastFoto.

For larger images, you can either scan the image or document in sections and then splice it back together using photo editing software such as Adobe Photoshop, or you can scan it on the copiers available at any GCPL branch. Branch copiers scan material up to 11"x17". The copiers are also capable of scanning at higher resolution (up to 600 dpi).

Can I scan at high resolution?

Yes. The default setting for the equipment is high resolution (300 dpi) and JPG files. This suffices for personal collections and sharing with loved ones. You are welcome to change the settings to higher resolution (600-1200 dpi) and save TIFF files.

Should I scan at high resolution?

Higher resolution images are great for recording details, providing nuance and clarity for editing or preservation. 600 dpi (dots per inch) is the lowest standard for images at archives and museums as some projects are saved at 800-1200 dpi. High resolution TIFF files are also the archival standard over JPG as they never lose information.

However, higher resolution images are much larger and require more storage, and take longer to scan. For example, JPG files tend to be much smaller than TIFF files, making them better for sharing online or sending to friends and family. Many TIFF files may not be able to be sent via email, as the file is larger than the maximum email attachment size (often 25MB).

You can save a JPG and TIFF copy of each image if you desire for maximum preservation and accessibility.

Can I listen to the video, cassette tape, or vinyl record as it digitizes?

Yes, every Digital Legacy Lab PC has headphones plugged into it. You can adjust the volume as needed.

Will the sound for a VHS tape be loud enough? I tried digitizing it before and it is too quiet.

In the Honestech software, you can access the audio settings under Option. You may be able to increase the volume there. Always check to make sure the sound is being recorded from the VHS to DVD option. If it is still too quiet, this can be edited in the OpenShot video editing software available on the Digital Legacy Lab computer.

You can always play the VHS tape before recording and see how loud it can be. Some VHS tapes may be deteriorating which can alter the sound.

Can I buy a CD, DVD, or USB drive from the library?

Geauga County Public Library offers a limited supply of 4GB USB drives for purchase. Each USB drive is \$5, and can be purchased at the Reference desk. However, these USB drives are smaller than the recommended 8GB of storage, and should not be considered the recommended size. If possible, please bring your own device to your scheduled session.

The library does not offer blank CDs or DVDs for purchase.

Table of Contents

Digital Legacy Lab Frequently Asked Questions	i
Table of Contents.....	1
Policies and Procedures	2
Digital Legacy Lab Storage Recommendations.....	4
8mm and Super8 Film Converter Tutorial	5
Auto Feeder Scanner Tutorial.....	10
Camcorder Conversion	17
Cassette Tape Converter Tutorial	17
Flatbed Scanner Tutorial.....	32
Live Audio Recording Basics.....	41
Slides and Negatives Scanner Tutorial.....	47
VHS and DVD Conversion Tutorial	52
Vinyl Record Converter Tutorial	61
Saving to USB Drives and External Hard Drives	69
Saving Large Files to a Zip File.....	72
Transferring DVDs and CDs to USB	75
Saving Files to a CD or DVD.....	80
Troubleshooting Guide	86

Policies and Procedures

The Digital Legacy Lab is a digitization space to convert analog media to digital files. Each Geauga County Public Library Branch is equipped with a full Digital Legacy Lab.

Media formats that can be digitized are:

Audio

- Audio cassette tapes
- CDs
- Live audio
- Vinyl records (33 1/3 and 45 rpm)

Video

- 8mm and Super8 film
- 8mm cassettes, Hi8, and MiniDV
- DVDs
- VHS and VHS-C

Images and Documents

- Documents and photos (up to 8.5"x11")
- 50mm slides
- Film and photo negatives
- Large format film

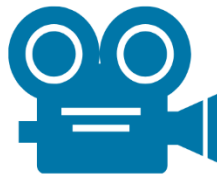

Audio Formats	
Vinyl (33 1/3 & 45rpm) Audio Cassettes CDs Live audio	
Video Formats	
8mm film Super8 film 8mm cassettes Hi8 film	DVDs Mini DVDs Mini DV tapes VHS and VHS-C
Image and Document Formats	
Documents and Photographs (up to 8.5"x11") 50mm slides (135, 126, & 110) Film and photo negatives (135, 126, & 110) Medium Format Film (up to 2.36"x8.66") 4" x 5" Film Large format film (up to 8"x10")	

Available by request: 78rpm vinyl records; 8mm and Super8 negatives

The Digital Legacy Lab includes editing software to assist patrons with digitization and other personal design projects. Available software includes:

Image Editing

- Adobe Photoshop
- Adobe Lightroom
- GIMP
- Inkscape
- Krita

Video Editing

- Adobe After Effects
- Blender
- OpenShot

Audio Editing

- Adobe Audition
- Audacity

Also included from the Adobe Creative Cloud: Illustrator, InDesign, Dreamweaver, Animate, etc.

Overall process for accessing the Digital Legacy Lab

The Digital Legacy Lab is free to use and available during library hours. The Digital Legacy Lab closes 30 minutes before the library.

All patrons must sign the Digital Legacy Lab User Agreement before using the lab. This is a digital form patrons can sign on the Digital Legacy Lab computer. It is located on the Desktop.

The Digital Legacy Lab uses Windows PCs. When bringing in USB storage devices, be sure that the device is compatible with the Digital Legacy lab PCs.

In-person training is available at least once a month. It includes an overall explanation of the Digital Legacy Lab and the equipment, watching video tutorials, and answering questions. It is not mandatory to attend the in-person training. Online training is available on the library's website.

Written and video tutorials are available for reference and step-by-step information about the digitization equipment. The written tutorials are available in physical copy in the DLL binder. The video tutorials are also available on the Geauga County Public Library website.

The Digital Legacy Lab is completely self-service. Patrons are expected to do all digitization projects by themselves or with the help of their own assistant such as a family member or friend. The assistant(s) must also sign the Digital Legacy Lab User Agreement before using any of the equipment.

One-on-one support for digitization projects is available during consultation hours with the Digitization Specialist. Consultation hours are at least once a month at each branch. To schedule time during consultation hours, sign up to use the Digital Legacy Lab during the available hours. Hours are posted outside of each Digital Legacy Lab, and on the Geauga County Public Library website. Patrons do not need to register for consultation specifically.

Branch staff assist with troubleshooting issues only. Branch staff will not help with digitization or stay in the room with patrons.

Call or talk in-person to any Geauga County Public Library Reference desk to schedule time in the Digital Legacy Lab. Patrons can also schedule an appointment online via the Geauga County Public Library website.

Digital Legacy Lab Storage Recommendations

GCPL IT Department recommends patrons bring a **USB drive** or other storage medium with at least **8 GB** of available storage to ensure they have plenty of space for any assortment of possible files.

That said, smaller drives are perfectly welcome if the patron knows how much space their digitized files will use. Some sample file sizes for typical media files are listed below, but **actual file sizes can vary greatly** based on a variety of factors including length of media, amount and type of “information” being stored, variations in settings and encodings, and many other variables.

Images

- PNG ~ 50 – 250 kB
- GIF ~ 100 – 300 kB
- JPG ~ 20 – 300 kB
- BMP ~ 1 – 15 MB
- TIFF ~ 1 – 15 MB

Documents

- DOCX ~5 – 200 kB per page
- PDF ~ 10 – 300 kB per page
- ODT ~ 80 – 90 kB per page

Media Files

- eBook ~ 1 – 5 MB
- MP3 song ~ 3 – 4 MB
- FLAC song ~ 10 – 15 MB
- DVD Movie ~ 4 GB
- HD Movie ~ 5 – 8 GB
- Blu-Ray Movie ~ 20 – 25 GB

How much media fits on 8GB?

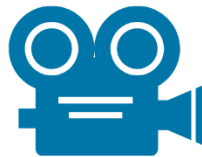

Audio Formats
~2500 3min songs (mp3)
~600 3min songs (FLAC)
~30 10 hour audiobooks

Video Formats
3-8 hours of video (720p)
1-3 hours of HD video (1080p)
10-15min UHD/Blu Ray video (4K)

Image and Document Formats
~3500 photos (jpg)
~500-1000 images (tiff)
~2500 ebooks (epub or pdf)
10,000-19,000 documents (docx or pdf)

All sizes are examples. Actual file size will vary greatly depending on media length, quality, storage settings and encoding, etc.

Patrons may save their files to DVDs or CDs at all Digital Legacy Lab locations. However, this is **not recommended** as DVDs and CDs hold less storage than a USB drive and are harder to access as CD/DVD drives are not included in new technology. Patrons will need to migrate the files again soon.

8mm and Super8 Film Converter Tutorial

The Digital Legacy Lab can convert 8mm and Super8 film with the Wolverine MovieMaker Pro. It digitizes slower than real time, at least 5x slower than watching the film normally.

Table of Contents

Set up the Machine.....	5	Copy Files.....	7
Recording.....	6	Troubleshooting.....	9
Rewind.....	7		

Set up the Machine

1. Make sure the converter is turned on.
2. Push the film door tab left to flip open the door.
3. Mount the Reels and Film. If your film reel has 8mm (small) mounting hole, mount the reel directly to the left shaft, otherwise use the provided red color reel adapter
 - a. If adapters are needed always place Red on the LEFT side, Grey on the RIGHT side.



- b. Mount the included 5" reel to the right shaft.
- c. Route the film according to the diagram on the face of the device.

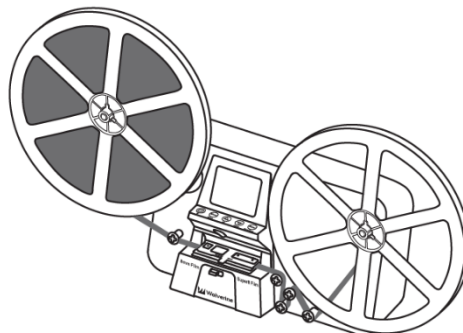

4. Slide open the flap door, putting the film sprocket holes at the top. Place the film underneath the 3 white tabs.
 - a. Place and hold film underneath Tab #1

- b. Twist film slightly and clip film underneath Tab #2

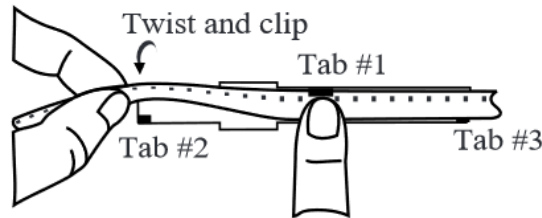

- c. Twist film slightly and clip film underneath Tab #3
- 5. Make sure the film is placed properly, then close the flap door.
- 6. You can make the adjustment of the Movie Register (the film center X and Y). It needs to be adjusted before recording if the default setting is off.
 - a. If the image is showing clearly on the screen, skip this step.
 - b. Choose Frame ADJ from the Menu and press Enter.

Film type:
X adjust, Enter
 X:
 Y:
 W:

← 8MM or SP8

← Select X or Y or W by pressing Enter button

X = shift center to left or right

Y = shift center up or down

W = zoom-in or zoom-out

↑
Adjust the values of X, Y, W by pressing Up or Down buttons

- c. Once satisfied with how the image looks on the screen, press Menu to get back to the Main Menu screen.

Recording

1. Have Record highlighted on the Menu screen. Press the Up and Down button to get to Record. Press Enter.

Record Playback Rewind (More ▼)	Exposure Sharpness USB (More ▼)	Frame ADJ Language Format (More ▼)	Default Setting Version (More ▼)
1st page	2nd page	3rd page	4th page

2. Select the film type using the Film Selection Lever, then press Enter/Start button to start recording.

- a. For 8mm, push the lever to the left. For Super8, push the lever to the right.
- b. While recording is in progress, a red dot will blink at the upper left corner.
- c. Each image will show on the screen.

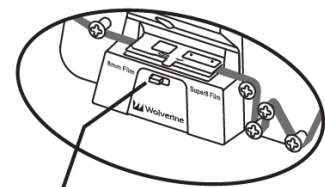

Film Type Lever

- d. The file counter at the lower right corner will increase by one after each recording stop. This number represents the filename of the current recording film.
- e. Press Enter to stop recording.

Rewind

1. Open the flap door and remove film, then close the flap door. Confirm the flap door is not in the way of the rewinding process to prevent film from being scratched.
2. Swap reels. Place an empty reel on the right-side shaft and place film perforation holes on the outside (as shown). Use adapters if needed.

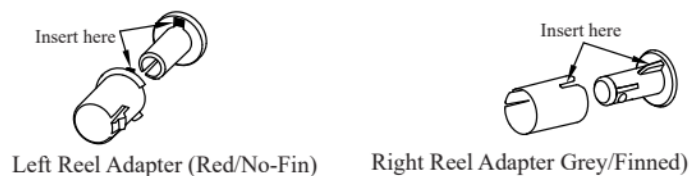

3. Follow the dotted line diagram on the converter, select Rewind in the Menu by pressing the Up and Down buttons. Press Enter. When finished, press Enter again to stop.

Copy Files

1. Press Menu on the converter and then press the Up or Down buttons to USB(More). Press Enter.
 - a. The screen will say “USB Upload.”
2. Go to File Explorer  on the computer. The converter will show up as a USB Drive (the drive letter may change depending on what else is currently running on the computer.)

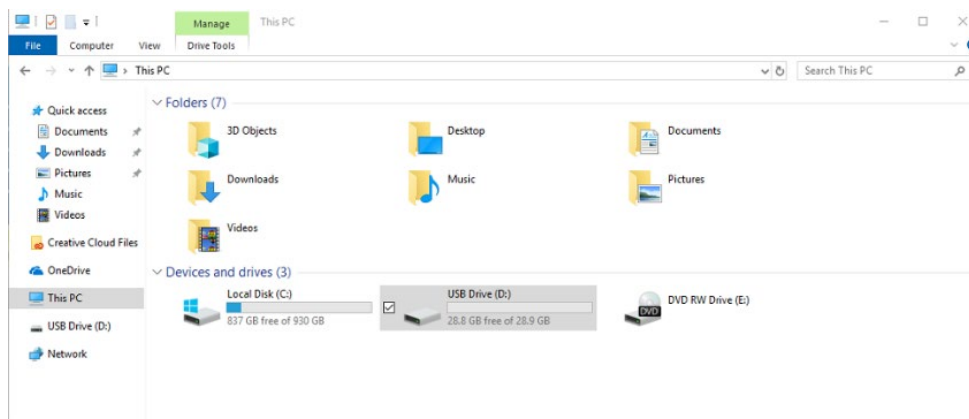

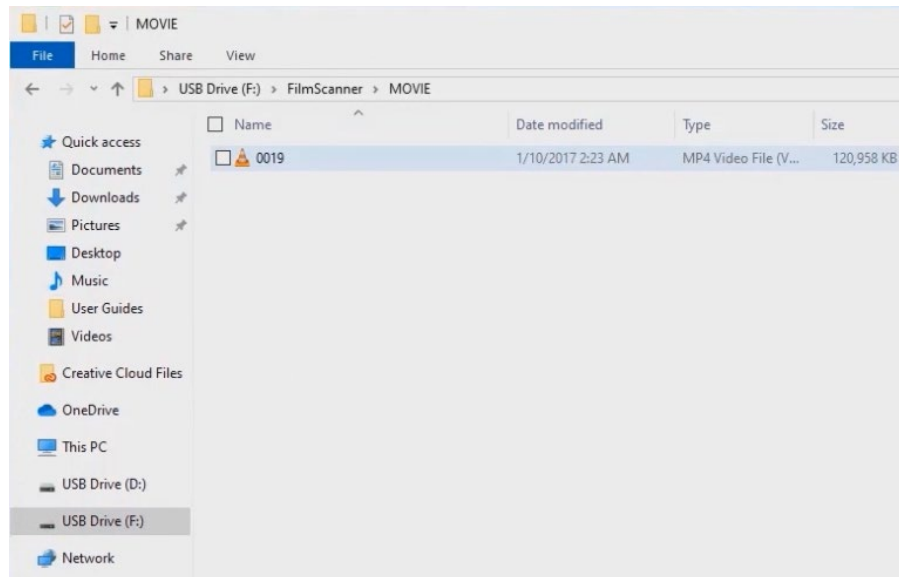

3. Double click on Film Scanner, then MOVIE. Your files are in this folder.



4. If you have not yet, plug your USB drive into the computer.
5. Click and drag the folder of your tracks to your USB drive.
6. **Make sure to delete your files from the converter.**
 - a. Option 1: Delete the files from the MOVIE folder on the computer.
 - i. In the MOVIE folder, press Ctrl+A to select all.
 - ii. Press the Delete icon in the folder.
 - b. Option 2: Delete from the converter.
 - i. Press Menu on the converter.
 - ii. Press the Up and Down buttons until Format is highlighted. Press Enter.
 - iii. Choose Yes with the Up and Down buttons and press Enter to delete all files from the converter

Files MUST be manually deleted from the converter. They will not automatically delete.

Troubleshooting 8mm and Super8 Film Converter

Issue	Reason	Solution
My film will not advance through the machine	Film has imperfect splices, film is bent, or broken sprocket holes	Open the flap door while film is stuck, move the problem frames forward. Then close the flap door and continue recording
Some segments are jittery and some are not	Sprocket holes may be damaged from film being played too many times	Try recording and converting the film backwards to use the good edge of the sprocket holes. Then use software to reverse the video
 <p style="text-align: center;">Imperfect/Bad edge sprocket holes Normal ←Bad edges→ </p>		
My film won't go through the machine	Some old film is wider than 8mm at some sections due to loose manufacturing	Place a piece of paper carefully in the track table to keep it wide enough to fit this film
		
The speed of the video is too fast/slow		Edit in software such as Adobe Premiere or VLC Media player
My film is offset.	Film bed needs to be adjusted to center on your film.	<ol style="list-style-type: none"> 1. On the film converter, select Menu. 2. Navigate to Frame ADJ using the arrow buttons. Press enter. 3. Select X (left/right), Y (up/down), or W (zoom in/out) by pressing the Enter button, then adjust with the arrow buttons.

Auto Feeder Scanner Tutorial

The Epson FastFoto FF680W scanner can scan photographs and documents up to 8.5 x 11 inches. All scans are at least high resolution at 300 dpi.

Table of Contents

Preparing Photos	10	Scanning.....	12
Original Document Specifications.....	11	Troubleshooting.....	16

Preparing Photos

Before coming to the Digital Legacy Lab, prepare your photos and documents for easy scanning.

1. Use a soft, dry cloth (like the microfiber cloth, one is available in the Digital Legacy Lab) to wipe the front and back of your photos to remove dust, dirt, or other particles that could potentially scratch your photos.
 - a. **Caution:** Because of the speed at which photos are scanned, dust particles on your photos can cause straight lines to appear in scanned images, and in extreme cases can lightly scratch the protective finish on your photos.
2. Organize your photos by date or subject.
 - a. When scanning, you can name the images using the year, month or season, and subject, such as "1970_Summer_Vacation".
 - b. Organizing the photos can save time in the future.
3. Check the following if you are scanning various sizes of photos:
 - a. If you have both landscape and portrait photos of the same size, you can stack them together and scan them in one batch. You can rotate the images as necessary after scanning by clicking Edit > Rotate Left or Rotate Right.
 - b. You can scan 4x6" and 5x7" photos in the same batch when the photos are grouped by size, with the larger photos at the back.
 - c. Do not mix documents and photos. Scan documents separately.
4. Make sure the photos:
 - a. NOT curled
 - b. Have NO sticky notes or adhesives on the back
 - c. Have staples and paperclips REMOVED
 - d. Do NOT stick to each other when shuffled.
5. Next, place the organized photos into the scanner.

Original Document Specifications

Photo Size	Loading Capacity
3.5 x 5 in	36 photos (thickness less than 0.009 in without photo curling)
4 x 6 in	
5 x 7 in	
8 x 10 in	30 photos (thickness more than 0.009 to 0.01 in without photo curling)
Polaroid Photos	10 photos
Photos in the carrier sheet	1 photo
Panoramic Photos under 12 in	1 photo
Panoramic Photos between 12.1 and 36 in	10 photos
	1 photo

Paper Type	Paper Size	Paper Weight	Loading Capacity
Plain Paper Fine Paper Recycled Paper	Letter (8.5 x 11 in)	7 to 110 lb	21 lb: 50 sheets
	Legal (8.5 x 14 in)		24 lb: 43 sheets
	A4 (8.3 x 11.7 in)		28 lb: 37 sheets
	A5 (5.8 x 8.2 in)		34 lb: 31 sheets
	A6 (4.1 x 5.8 in)		42 lb: 25 sheets
	B5 (7.2 x 10.1 in)		56 lb: 19 sheets
	B6 (5 x 7.2 in)		68 lb: 15 sheets
	A8 (2.1 x 2.9 in)	34 to 110 lb	110 lb: 9 sheets
			Loading capacity may vary depending on paper type
Paper Business Cards	3.5 x 2 in	Up to 56 lb	15 cards loaded horizontally

Caution: Do not load the following types of originals in the scanner, or they may be damaged or may damage the scanner:

- Photos with oil, correction fluid or tape, or other liquid or residue
- Photos with materials stuck on the back sides
- Photos with tape or stickers attached
- Sticky photos
- Photos that have been freshly printed or processed
- Photos with staples or clips
- Photos with curled corners
- Photos in shapes other than squares or rectangles (unless loaded in carrier sheet)
- Photos in large, uneven shapes (unless loaded in carrier sheet)
- Photos that are peeling
- Instant camera photo paper, including peel-apart or thermal-transfer types (other than sheet film types 3.5 to 4 inches [89 to 102 mm])
- Photos thicker than .011 inch (.3 mm)
- Photos longer than 36 inches (914.4 mm)
- Photos smaller than 2 x 2 inches (50.8 x 50.8 mm) (unless loaded in carrier sheet)
- Perforated photos (unless loaded in carrier sheet)
- Torn photos (unless loaded in carrier sheet)
- Fragile or aging photos (unless loaded in carrier sheet)
- Curved or wrinkled photos where the thickness of the stack is greater than .07 inch (2 mm) (unless loaded in carrier sheet)

Scanning

1. Make sure the scanner is on.
2. Open the input tray, slide out the output tray, and then raise the stopper.

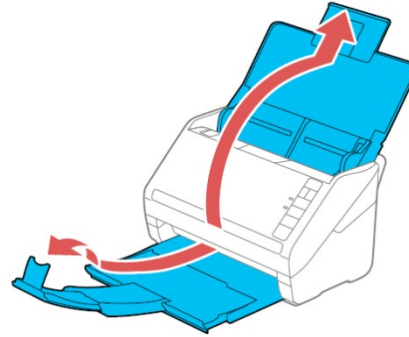

- a. If you want to scan large size photos such as 5×7" or 8×10", extend the input and output tray extensions.
 - b. Make sure you adjust the position of the stopper to correctly fit the size of the ejected photos. If not, photos may scatter.
3. Slide the edge guides on the input tray all the way out.

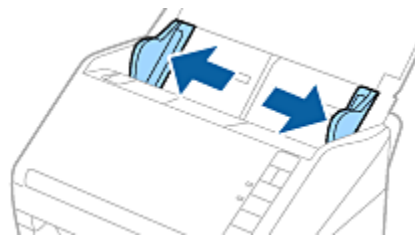

4. Load the photos into the input tray face up and top edge first. Slide the photos into the scanner until they meet resistance.

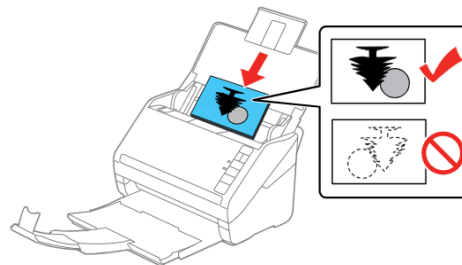

- a. For documents, place them face down and top edge first.

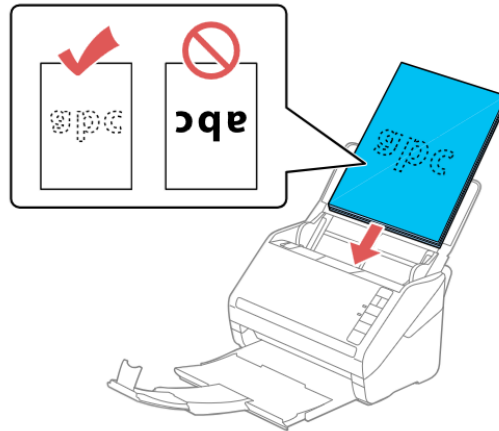

- b. Note: it is recommended to place the photos horizontally.
- c. If you are loading 4×6" and 5×7" photos in the same batch, align the middle of the photos and load them at the center of the input tray with the 5×7" photos at the back and the 4×6" photos at the front.

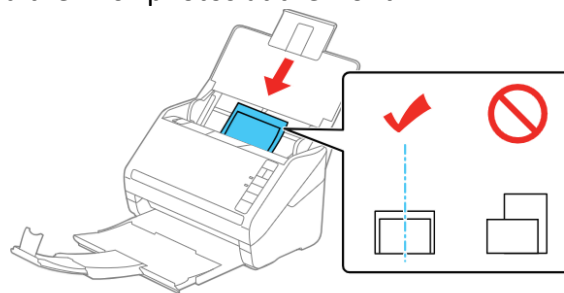

- 5. Slide the edge guides to fit the edge of the photos making sure there are no gaps between the photos and the edge guides. Otherwise, the photos may be fed skewed.
- 6. Click the button on the scanner to start scanning.  The software will launch automatically.
- 7. Set the save settings on the Describe Your Photos screen.

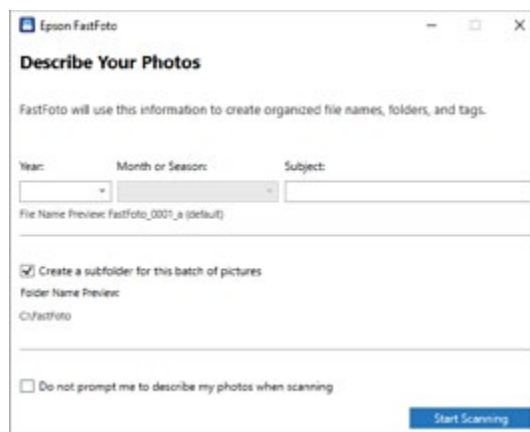

- a. Year/Month or Season/Subject: Set the file name settings.

8. Click **Start Scanning**.

- Note: If the glass surface dirt alert appeared when scanning, clean the glass surface inside the scanner after scanning.
- If multiple photos feed through at the same time, press the Slow Mode on the machine button to slow down the feeding speed. Press the button again to return to normal speed.

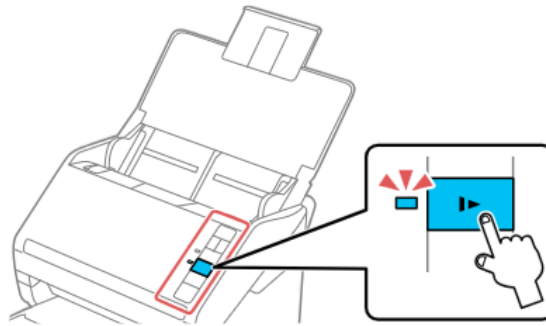

9. After scanning is completed, the following screen is displayed:



- If you want to continue scanning, click **Scan Next Batch**.
 - When you are finished scanning, click **Done Scanning**.
10. The photos are scanned and saved in the folder on the desktop or the location you choose.
11. Check the scanned images.
- The following rules apply to file naming:
 - No identifier is added: These are the original scanned images. No enhancements were applied.
 - Added "_a" at the end: These images include automatic color enhancements.
 - Added "_b" at the end: These are the scanned back sides of the photo.
 - You can enable back side scanning from **Settings > Scan Settings** tab.
12. After scanning, you can share, upload, or edit the images using the photo scanner. You can also change the view setting of thumbnails.
- You can rotate the scanned images automatically when scanning using Epson FastFoto.

- i. In the Epson FastFoto software, select the **Settings > Advanced Settings** tab, and then enable **Auto Rotation**.
- ii. Depending on the photos, they may not be rotated correctly.
 1. To rotate the scanned images manually, while in the software, select the image you want to rotate, and then click **Edit > Rotate Left/Rotate Right**.

Auto Feeder Scanner Troubleshooting

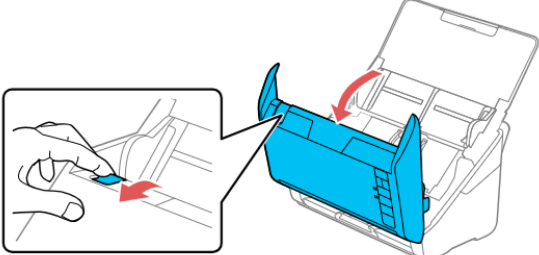
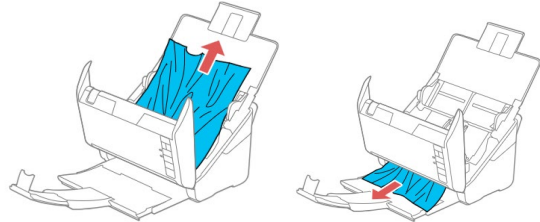
Problem	Solution
<p>Photo or document jam in scanner</p>	<ol style="list-style-type: none"> 1. Turn off scanner 2. Remove docs and photos from input tray 3. Pull down cover open lever to open the scanner cover  <ol style="list-style-type: none"> 4. Gently pull out any jammed originals from inside the scanner and from the output tray  <ol style="list-style-type: none"> 5. Close the scanner cover. Turn scanner on and resume scanning.
<p>Image is distorted or blurry</p>	<p>Make sure your original media is not wrinkled or warped, as this will distort the scan. If the image is still distorted,</p> <ol style="list-style-type: none"> 1. In the Epson FastFoto software, select Settings > Scan Settings 2. In Main Settings, be sure to select the correct Image Type for your media 3. In Advanced Settings, select Curled photo correction if your photos are curled.
<p>Scanned image colors do not match original colors</p>	<p>Printed colors never exactly match colors on the computer monitor because printers and monitors use different color systems.</p> <p>If you would like to adjust the colors in the scanned image:</p> <ol style="list-style-type: none"> 1. In the FastFoto software, select Settings > Scan Settings. Make sure to select the correct Image Type for your media 2. In the FastFoto software, select Enhance to let the program adjust the image resolution. 3. You can also adjust the image using editing software such as Adobe Photoshop.

Camcorder Conversion

The Digital Legacy Lab can convert Hi8 and 8mm video cassette tapes, and MiniDV tapes with the UCEC All-in-One USB 2.0 Video Capture converter. Use the adapter to connect to the appropriate camcorder.

If you have a working camcorder with an A/V output, you can use the Digital Legacy Lab equipment to digitize your tapes. Geauga County Public Library is not responsible for your equipment.

Table of Contents

Available Camcorders.....	17	Save Your Video Files.....	21
Setting up the Camcorder.....	17	Troubleshooting.....	25
Recording a Video from the Camcorder.....	19		

Available Camcorders



Samsung SCL810
Hi8 and 8mm cassette tapes

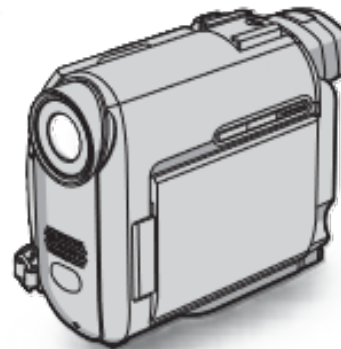

Sony DCR-HC20 or DCR-HC46E
MiniDV's

Setting up the Camcorder

For all camcorders, you should leave them plugged in and charging for the duration of your project. This will help avoid any loss of power. When you are finished, unplug the camcorder.

To set up the Hi8/8mm tape camcorder:

1. Connect the cable labeled 8mm/Hi8 to the camcorder. The plug should be inserted into the yellow plug labeled A/V OUT.

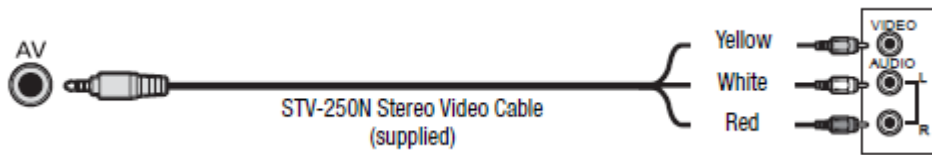

2. Connect the colored plugs to their corresponding color plugs on the All-in-One converter.
3. Turn on the camcorder. Using the dial to the right of the battery pack, turn the dial down to select PLAYER.



4. Insert the tape into the camcorder.
 - a. Press the TAPE EJECT button. The cassette compartment will automatically open.
 - b. Insert your tape and gently close the side of the compartment. The cassette compartment will close and slide back into the camcorder.
 - c. **Do not force the compartment closed or attempt to yank the tape in or out.**
 - d. If the tape begins playing, press STOP for now.
5. If you have opened the view screen, close it before beginning recording. Leaving it open will cause audio to play from the camcorder, not the Honestech software on the PC.

To set up the MiniDV camcorder:

1. Connect the cable labeled MiniDV to the camcorder.
 - a. To access the A/V OUT port, gently remove the cover on the side of the camcorder.

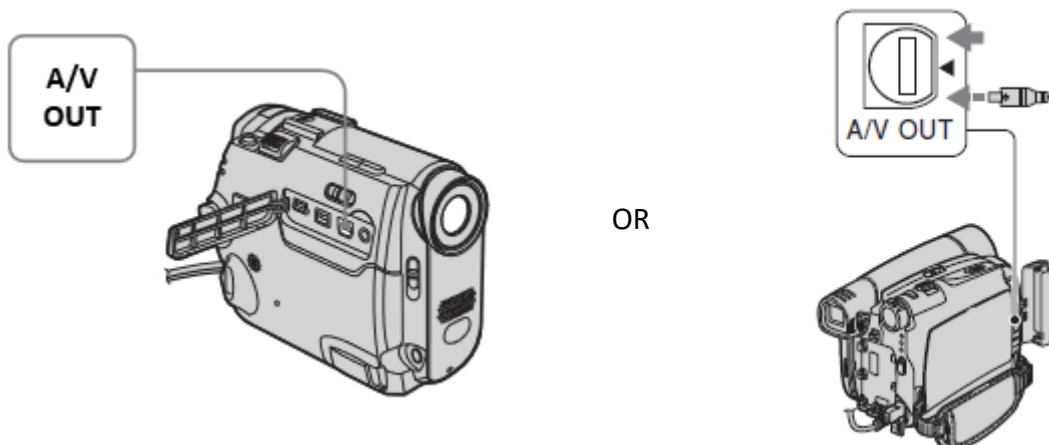

2. Connect the colored plugs to their corresponding color plugs on the All-in-One converter.
3. Insert the tape into the camcorder.
 - a. Slide the OPEN/EJECT lever in the direction of the arrow and open the lid. The cassette compartment should automatically open.
 - b. Gently press PUSH. The cassette compartment will close and slide back into the camcorder.
 - c. **Do not force the compartment or attempt to yank the tape in or out.**
 - d. Close the lid.
4. Turn on the camcorder and set the camcorder to PLAY/EDIT mode.
 - a. Open the viewscreen.
 - b. Slide the power switch repeatedly until PLAY/EDIT lights up.

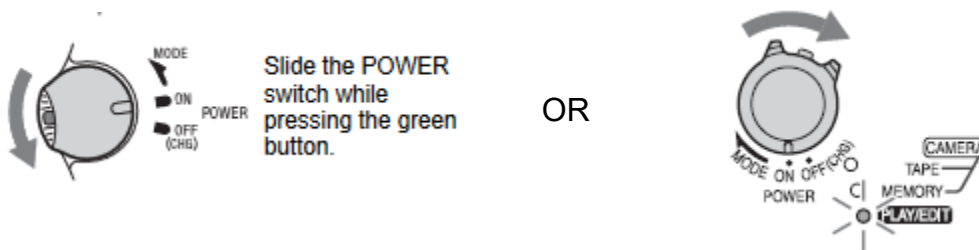

Recording a Video from a Camcorder

1. Make sure the appropriate camcorder is plugged into the All-in-One converter and turned on.



- a. This is the converter. Connect each plug to the matching plug on the cord attached to the camcorder.
 - i. Red to red, yellow to yellow, and white to white.
 - ii. The other end (USB connection) should be plugged into the USB strip.
2. If the camcorder starts playing, press STOP for now.
3. Double-click the **Honestech VHS to DVD 3.0** icon on the desktop.



4. If prompted, enter the product key for the software. If not prompted, skip to the next step.
 - a. The product key is located on the Honestech CD case in the DLL storage bin.
5. The Honestech window will open.
6. Click **Option**.

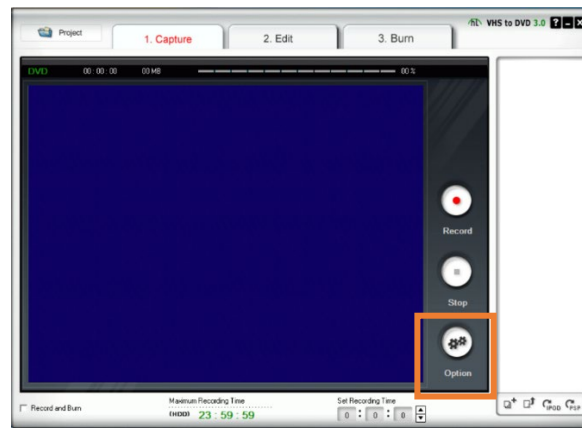

- a. Make sure the AV TO USB2.0 is selected for video.
- b. Make sure the audio is AV TO USB2.0.
- c. Click **OK**.

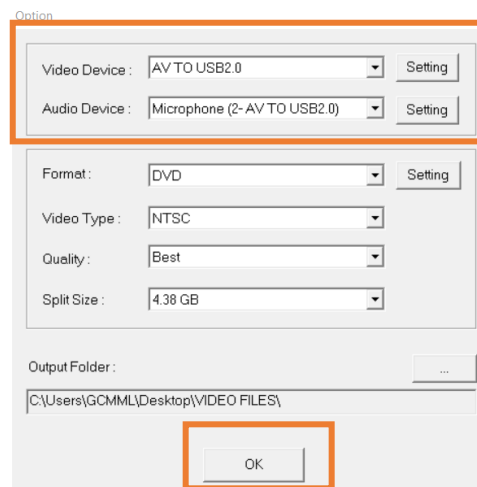

7. Press **Record** on the Honestech software and then press **Play** on the camcorder.
 - a. The tape will start to play and the software will record.

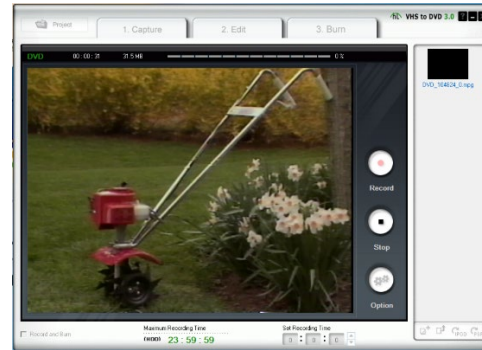
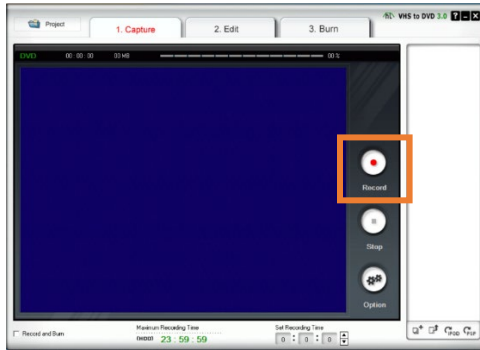

- b. You should see the video on the screen and hear the audio through the PC software.
 - i. For Hi8/8mm camcorders: If you hear audio through the camcorder and not the PC, close the view screen on the camcorder. You will need to restart the recording process to capture audio.
 - ii. For MiniDV camcorders: You will hear audio from **both** the camcorder and through the PC. This is normal.
- 8. When finished, press **Stop** on camcorder and then **Stop** in the Honestech software.

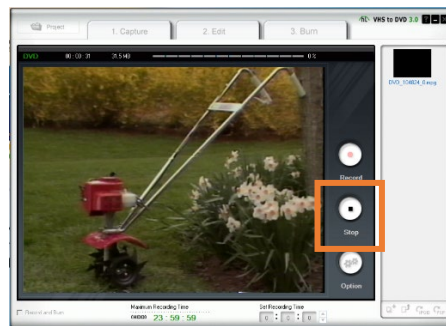

- 9. Rewind your cassette before ejecting from the camcorder.
- 10. Insert a new cassette to record another video.
- 11. When finished, save your files to a USB drive, or burn them to a DVD.

Save Your Video Files

Geauga County Public Library recommends saving your files to a USB drive (also known as a flash drive or memory stick) with at least 8GB of storage data. USB drive come in many sizes, so choose the size best for your projects and budget.

- 1. Close or minimize the Honestech window.

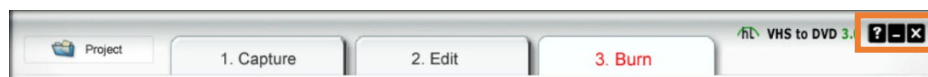

2. Files are saved to the Documents folder in the File Explorer.
 - a. Click on File Explorer in the taskbar.
 - b. Click on Documents
 - c. Double click on the VHS to DVD folder.

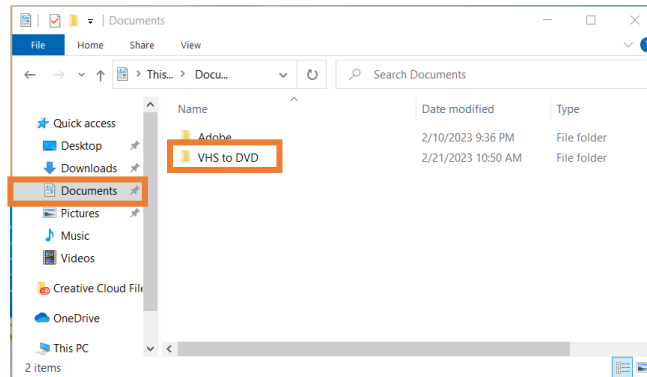

- d. If you changed the save location in the Honestech Options, locate that folder instead.
3. Highlight the files you want to save by clicking and dragging the cursor over them.
4. Click on the highlighted area and drag your files to your USB drive on the left.
 - a. If the files are large, try saving one at a time.

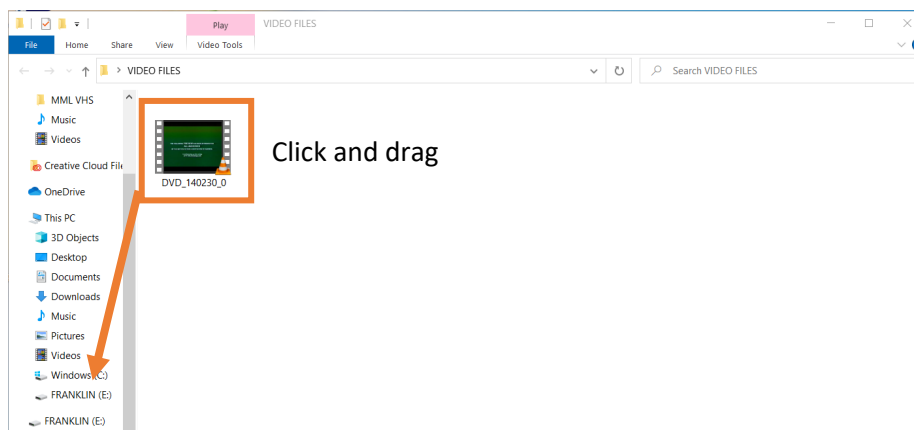

Burn to a DVD

There are multiple ways to burn a DVD. Here are the directions to burn a DVD in the Honestech software.

1. After recording the video(s) you want to burn to a DVD, click the **Burn** tab.
2. Click and drag the files on the right side of the screen to the middle of the software.



3. This will create a default menu that you can edit.
 - a. Double-click on the title ("My Title") to type in a new title



- b. Double-click on each file name under each video to change the name of each individual video and organize the videos.

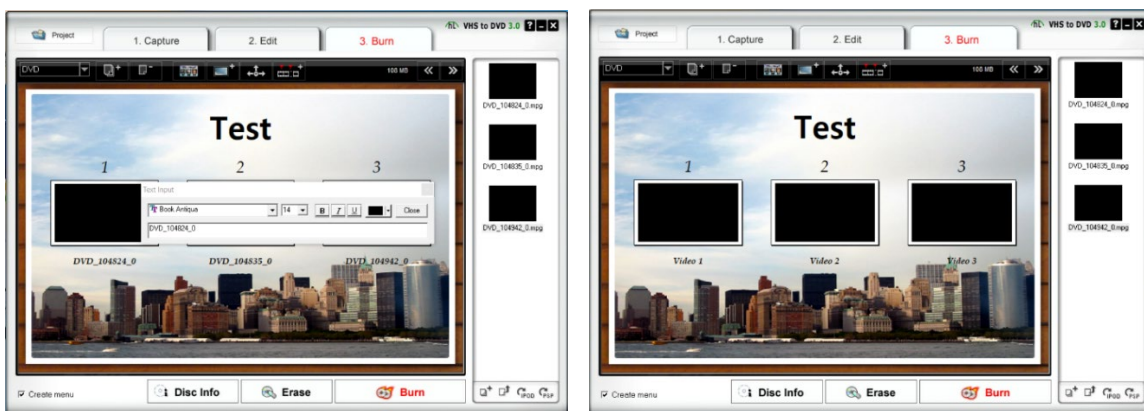

- c. If you do not want an automatic menu, uncheck the box next to "Create menu." The screen will change to this.

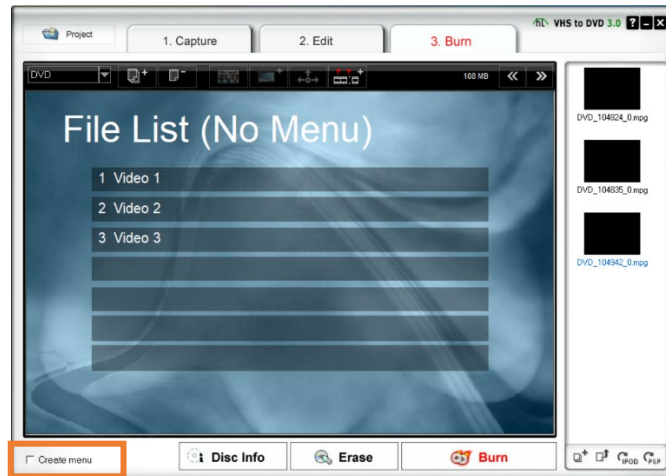

4. Insert the blank DVD into the computer.
 - a. Wait until the computer recognizes the blank DVD. This may take some time.
 - b. If the DVD is not recognized, try ejecting and re-inserting the DVD.
5. When ready, click **Burn** in the Honestech software.
6. The videos will be burned to the DVD and will be playable in a DVD player.

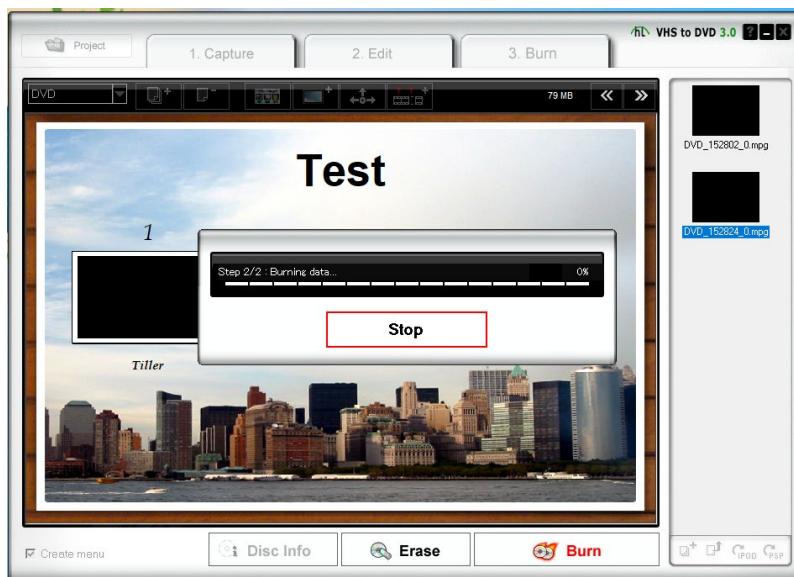

7. Eject your DVD from the computer.

Camcorder Troubleshooting

Problem	Cause	Solution
The device is playing but there is no video or audio playing on the PC	The All-in-One converter is not correctly plugged into the device.	Plug each cord into its color-corresponding plug on the device. Make sure that the USB cable is plugged in.
Cannot hear the recordings once saved and trying to play them on the computer	Computer audio output not set correctly.	Access the Settings > System > Sound . Under Output , select the device you are using to listen.
Audio is playing, but no video is playing on the Honestech software	The Honestech software options are not set correctly.	In Honestech, click Option . Make sure "AV TO USB 2.0" is selected for Video Device. Make sure "AV to USB 2.0" is selected for Audio Device. Select OK.
The AV to USB2.0 option is greyed out in the Honestech software	Computer volume mixer settings not set correctly	Close Honestech. Access the Settings > System > Sound . Under Advanced Options , select Volume Mixer . In the Input device dropdown menu, select AV to USB2.0 . Restart Honestech.
The Hi8/8mm camcorder is playing audio, but no audio is playing on the Honestech software	Camcorder speaker is on.	Close the camcorder LCD screen to turn off the camcorder speakers.
Cassette compartment will not open or eject a tape.	The camcorder is not charged.	Make sure that the battery pack is inserted into the camcorder correctly. Connect the charging cable to the camcorder and plug it into the power strip. Be sure to leave the camcorder plugged in while recording to avoid any loss of power.
Camcorder will not turn on.		
Camcorder turns off in the middle of recording.		
The MiniDV camcorder is playing audio at the same time that the Honestech software is, or with a slight lag.	This is normal.	

Cassette Tape Converter Tutorial

The Tascam 202MKVII cassette player can convert standard and CrO2 (chromium oxide) cassette tapes. Cassette tapes are digitized in real time.

Table of Contents

Record the Cassette Tape.....	26	Burn to a CD.....	29
Save Your New Music File.....	28		

Record the Cassette Tape

1. Make sure the cassette player is plugged into the USB port and turned on.
 - a. Find the cable behind the computer marked CASSETTE and plug it into an open port.
2. Press the **Eject** button on the cassette player and place the cassette tape into the machine. Close the door.



3. Open the Audacity software on the DLL desktop. The Audacity icon looks like this:



4. Press the Record button on the software. The Record button is a red circle.

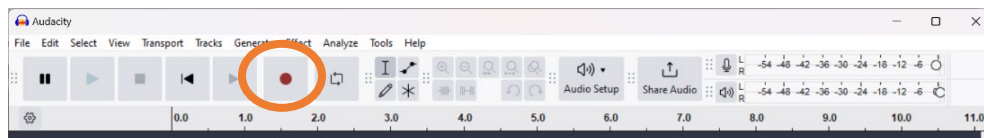

5. Press Play on the cassette player.



6. Audacity will begin recording your tape.

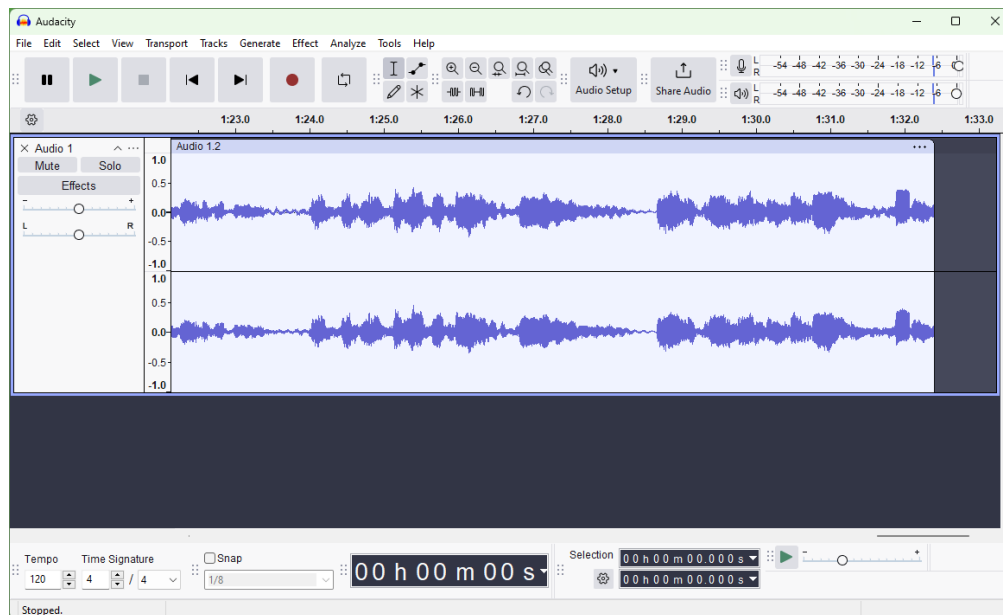

- a. If you can't hear the tape playing as it records, make sure the Software Playthrough is on.
 - i. Click Transport → Transport Options → Enable audible input monitoring
 - ii. There should be a checkmark next to "Enable audible input monitoring." If there is not, you won't hear the sound as it records.
7. When the tape stops, press the Stop button on Audacity. The Stop button is a black square.

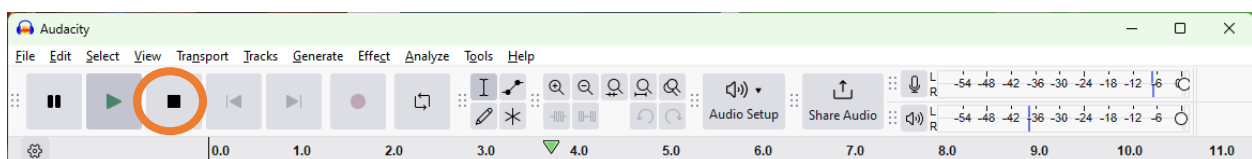

Save Your New Music File

1. In Audacity, click File. Then select Export Audio.

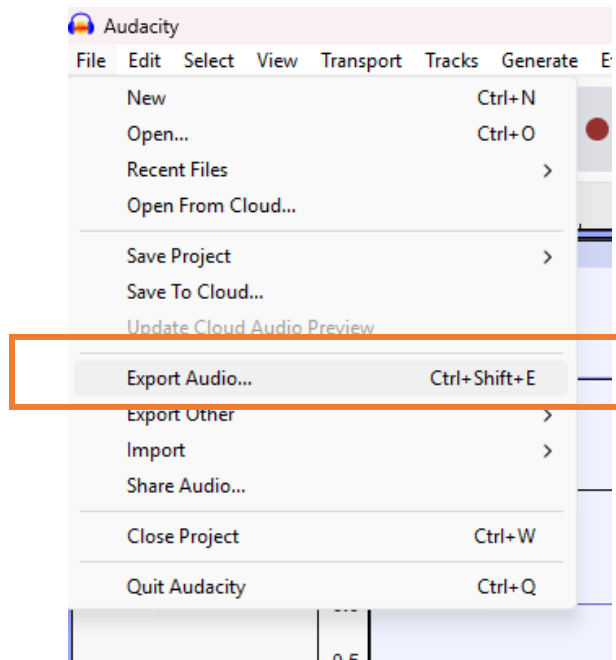

2. Title your track and select your format. You can also edit your metadata, or change where the file will be stored. When finished, press Export.
 - a. In most cases, you will be fine with an MP3 or WAV file.
3. Save your file to your USB drive by selecting **Browse**, then selecting your drive.

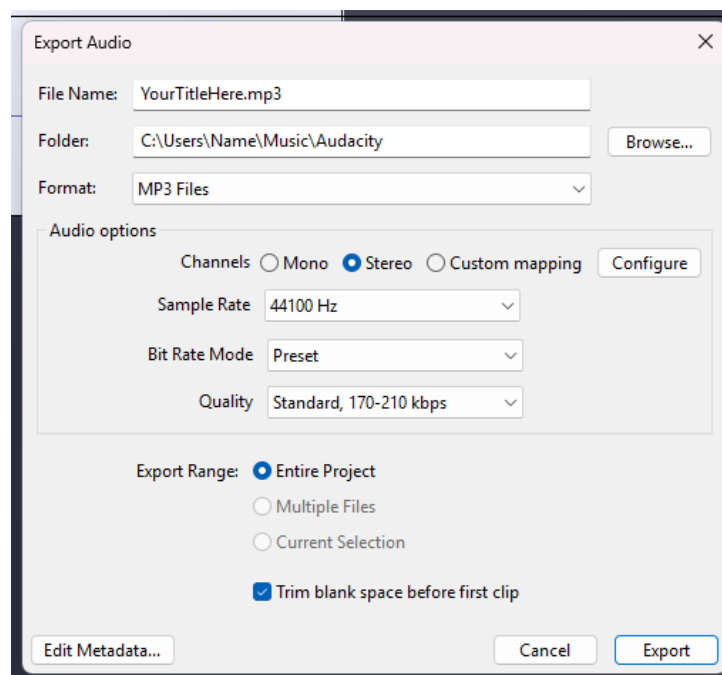

Burn to a CD

1. Insert the blank CD into the computer using the CD/DVD drive.



2. Left-click and drag to highlight all the files you want to burn to the CD.

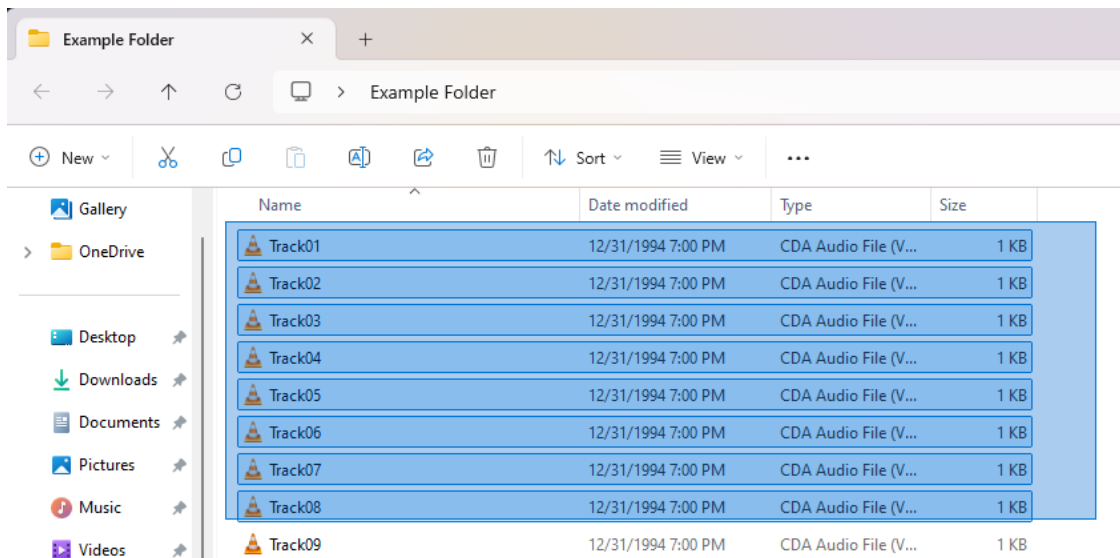

3. Click on the three-dots icon (. . .) in the top File Explorer menu.

4. Select **Burn to disc**

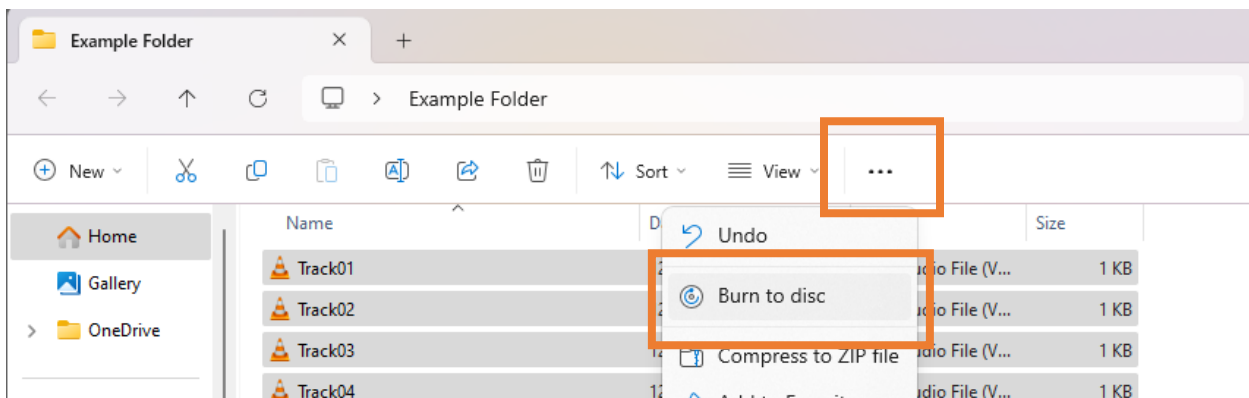

5. In the next window, select **With a CD/DVD player**. Click **Next**.
 - a. You can also name your disc in this window.

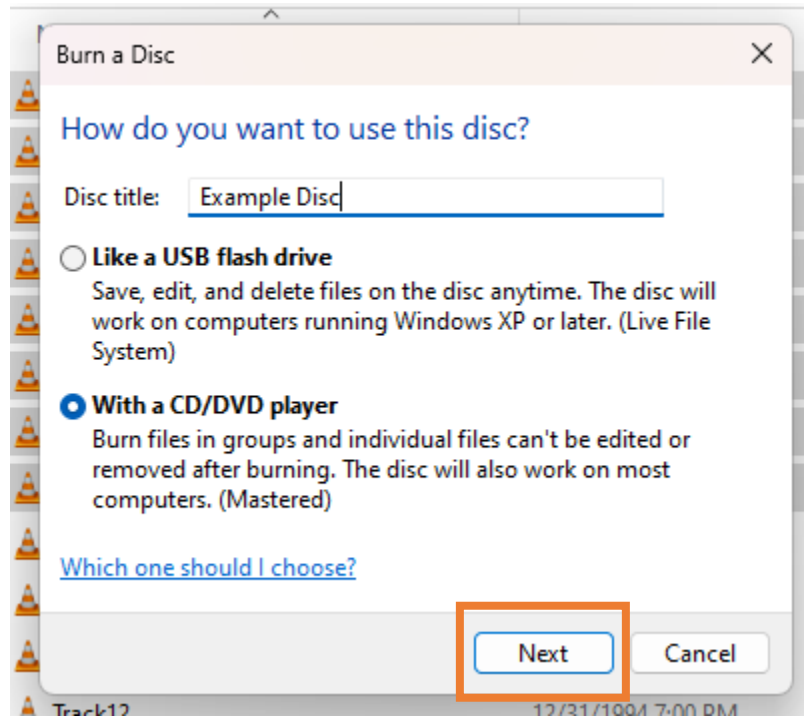

6. The next window that opens will be the CD. Click on the three-dots icon (. . .).
7. Click **Finish burning**.

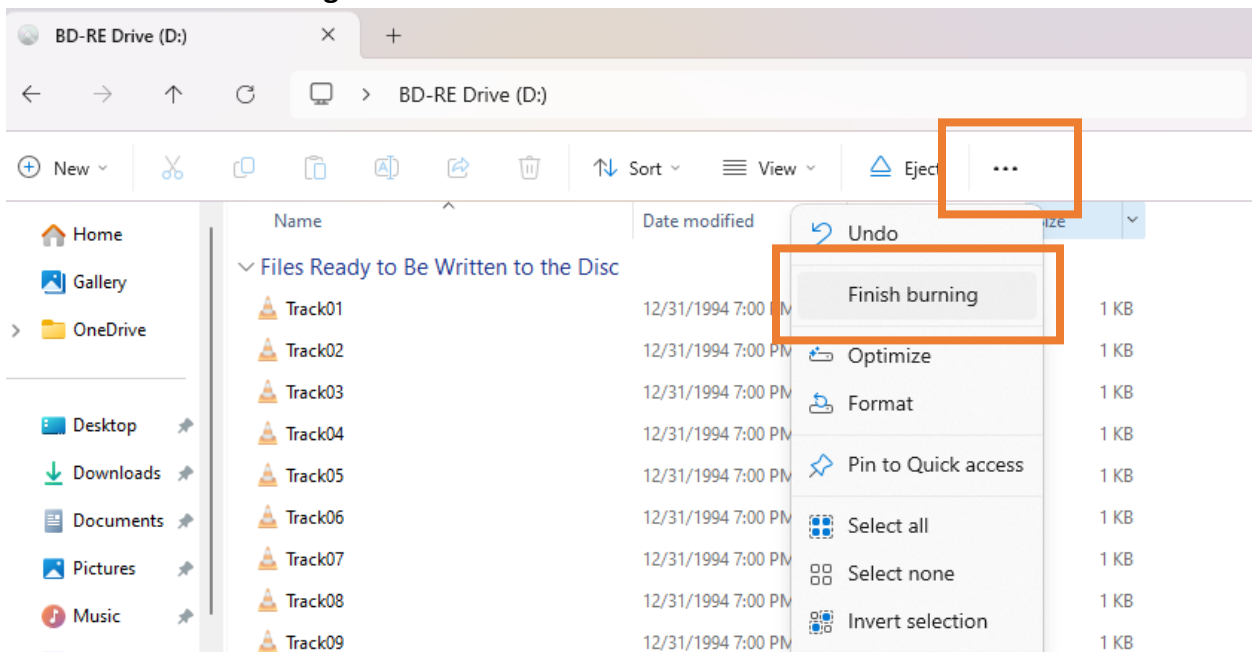

8. Click **Next**.

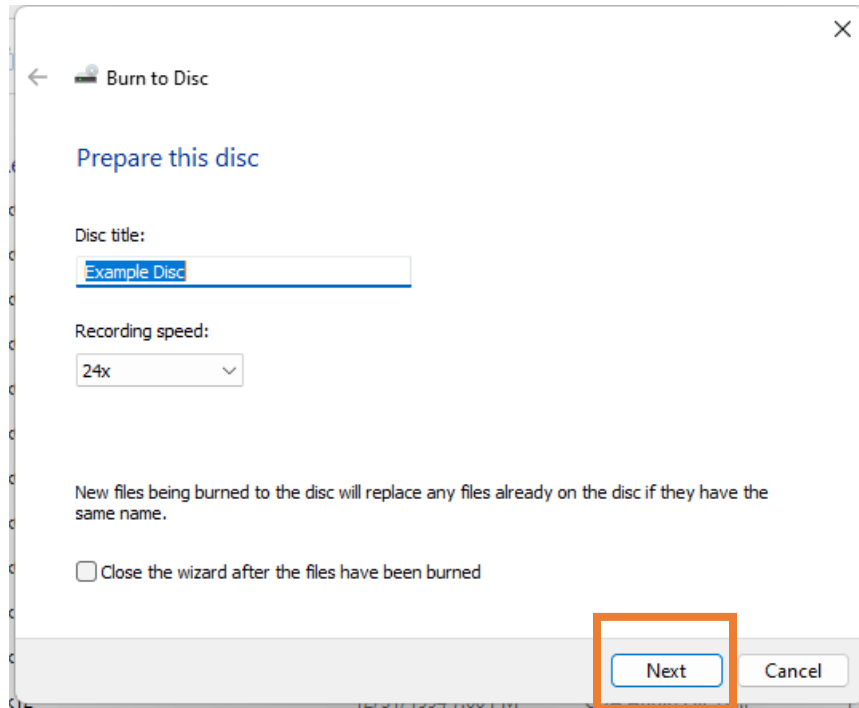

9. Once the CD has finished burning, the CD should automatically eject from the drive. If it does not, select **Eject** in the File Explorer menu.

Flatbed Scanner Tutorial

The Epson V850 Pro flatbed scanner scans photographs and documents up to 8.5x11 inches as well as slides, negatives, and large format film. It is great for delicate items and books or scrapbooks.

Table of Contents

Scanning Photographs and Documents.....	32
Scanning Slides, Negatives, and Large Format Film.....	33
To Save to a USB Drive.....	39

Scanning Photographs and Documents

1. Make sure the scanner is turned on.
2. Open the scanner cover. Make sure the document mat is installed inside the cover.

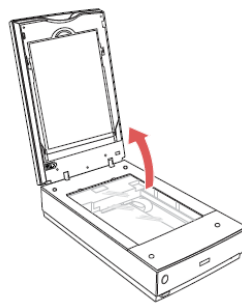

3. Place your document or photo face down on the document table. Slide the material to the top right corner of the scanner.
 - a. When scanning multiple photos at once, position each photo at least 20mm (0.8 inches) apart. For a large batch of photos, the auto feeder scanners are recommended.

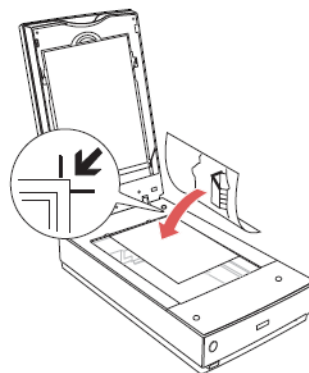

4. Close the scanner cover gently so that your original does not move.
5. Click the scan button  on the scanner to start scanning. The software will launch automatically.
 - a. If the software does not open automatically, double click on the Epson Scan icon on the desktop.



6. Click the 'Scan' button in the Scan Software.
 - a. The default mode should be Full Auto Mode. If you want to change the file type or resolution, try a different mode. **It is recommended to keep it in Full Auto Mode.**

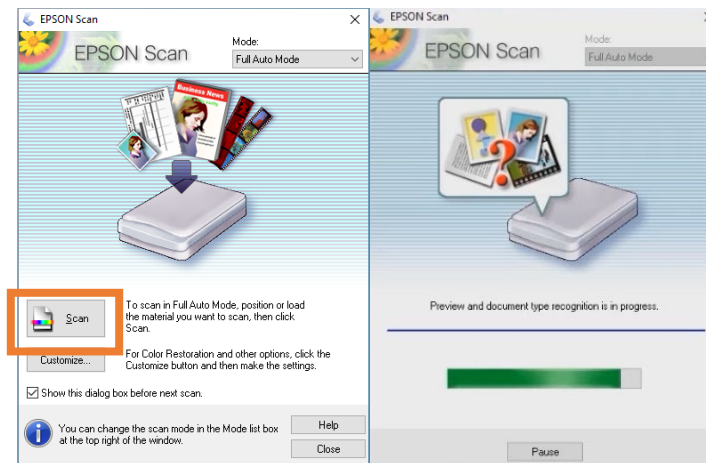

7. The flatbed will now scan. If there are multiple images spaced correctly, the scanner will recognize them.
8. The files are saved in the Pictures folder on the PC desktop. The folder should open automatically after the scan is finished. To access:
 - a. Open the File Explorer on the PC taskbar.
 - b. Select the Pictures folder.
 - c. Open the file to view or edit the files.
9. Highlight the files you want to save. Click and drag them to your USB drive.



Scanning Slides, Negatives, and Large Format Film

1. To scan film strips or slides, you need to remove the document mat from the scanner cover. This uncovers the transparency unit window so your scanner can use it to scan your film or slides.
 - a. Make sure the transparency unit transportation lock is unlocked.

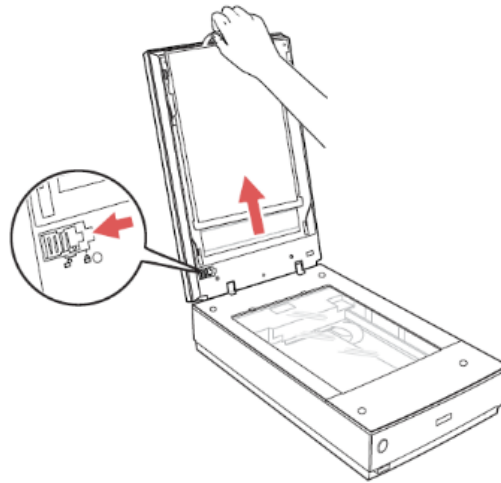

2. Use a soft cloth to wipe the transparency unit window and document table. A microfiber cloth is available in the DLL material storage bin.

3. Insert your media in the holder as shown below:

- a. **35 mm film strips:** Remove the top layer of the holder. Place the film inside, then lock the top layer over it.

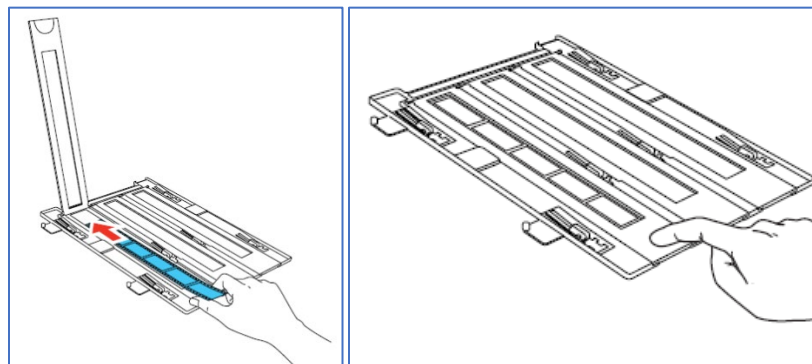

- i. Turn the film holder over and add it to the scanner.

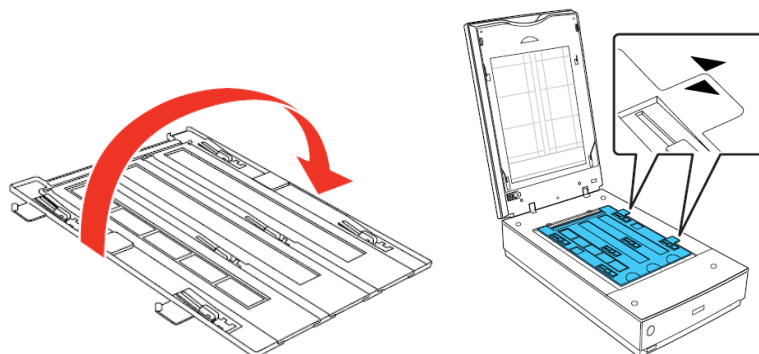

- b. **Medium format:** Open the top layer, slide the medium format into the holder shiny side facing up, then close the top.

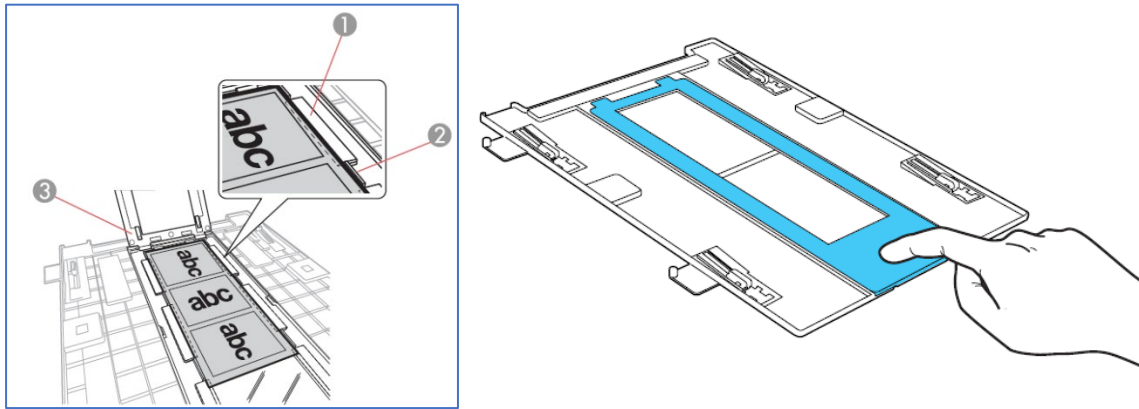

- i. Note: the film holder may not hold the outer edges of the film completely flat against the plate; this is normal and will not affect the quality of the scanned image.
- ii. Turn the film holder over and place in scanner.

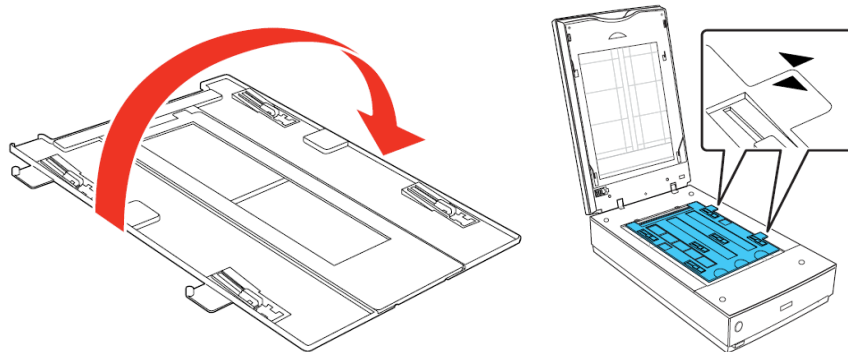

- c. **4 x 5 inch Film:** Gently place the film in the film holder. Hold only the edges or you may damage the film.
 - i. Note: Make sure the white areas on the back of the holder are not scratched, dirty, or covered in any way.

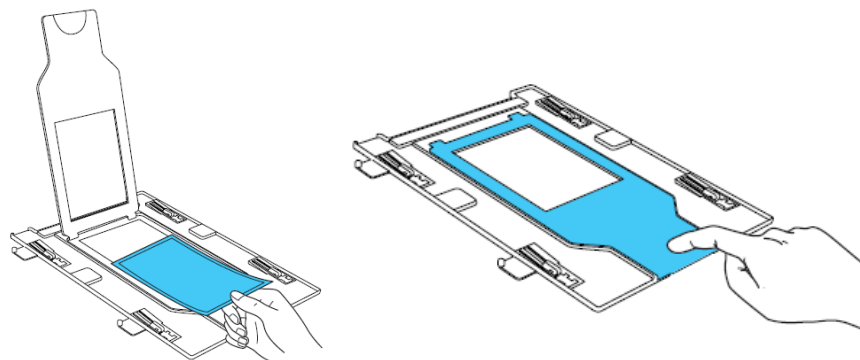

- ii. The edges of the film may need to be trimmed to fit in the tray.

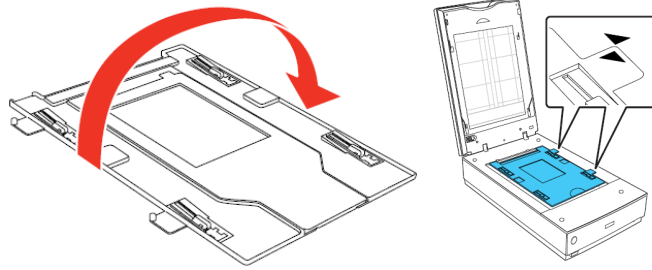

- iii. Turn the holder over and place it in the scanner.

- d. **35mm Slides:** Gently place each slide into a spot. Try to have them face the same way. It does not matter if any slides are backwards, this can be fixed in editing.
 - i. Place up to 12 slides in the slide holder, shiny side down.

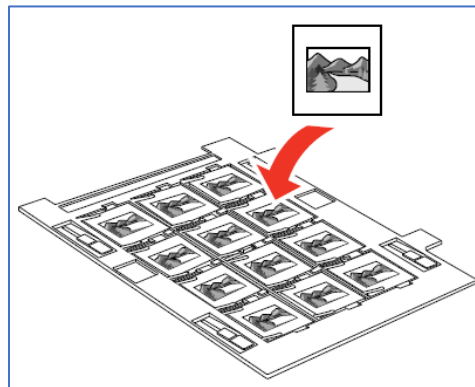

- ii. Place the holder in the scanner as shown. Align the arrows on the holder with the arrows on the scanner.

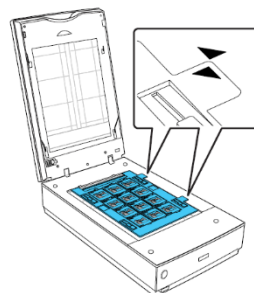

- 4. Carefully close the lid to the scanner.
- 5. Click the scan button on the scanner  to start scanning. The software will launch automatically.

- a. If the software does not open automatically, double click on the Epson Scan icon on the desktop.

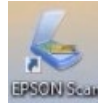

6. Click the 'Scan' button in the Scan Software.
 - a. The default mode should be Full Auto Mode. If you want to change the file type or resolution, try a different mode. **It is recommended to keep it in Full Auto Mode.**

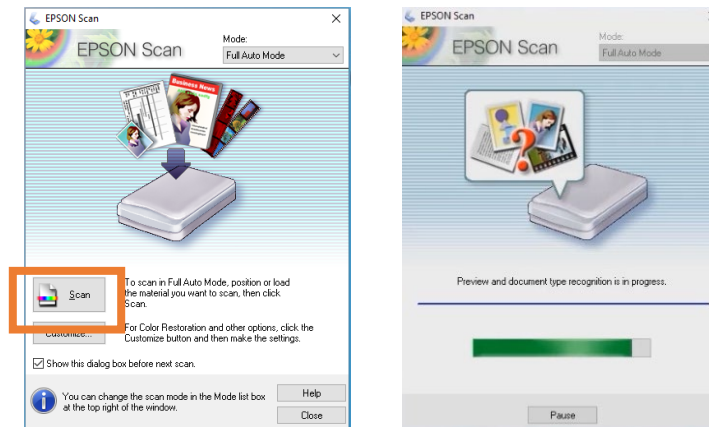

7. The flatbed will now scan. If there are multiple images spaced correctly, the scanner will recognize them.
8. The files are saved in the Pictures folder on the PC desktop. The folder should open automatically after the scan is finished. To access:
 - a. Open the File Explorer on the PC taskbar.
 - b. Select the Pictures folder.
 - c. Open the file to view or edit the files.
9. Highlight the files you want to save. Click and drag them to your USB drive.
10. When you are done scanning slides, replace the document mat on the scanner cover.



To Save to a USB Drive:

1. Plug in your USB drive into a USB port on your computer. The USB ports on the Digital Legacy Lab PCs are located on the right side of the screen.



2. Locate the folder on the desktop where your files are stored.
 - a. You can also open This PC and check the Documents or Photos folders if you cannot locate them. The library has set up the save locations, but sometimes these can change depending on the software. You can check where they are saved in the software.

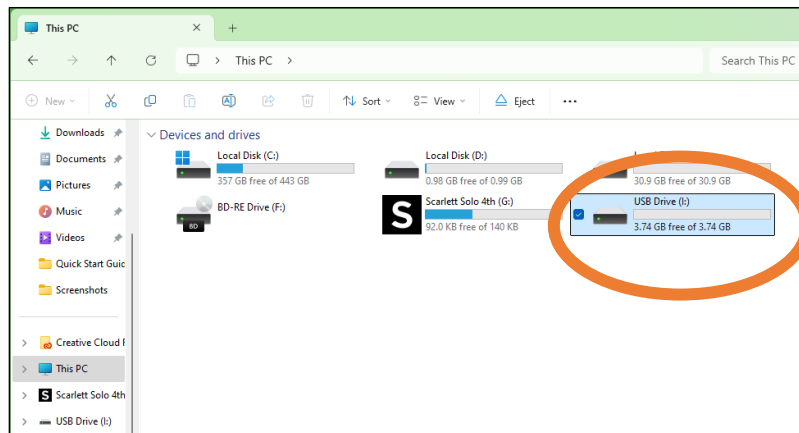

3. Highlight the files you want to save by clicking and dragging around the files with the left mouse button. You can also move them one at a time.

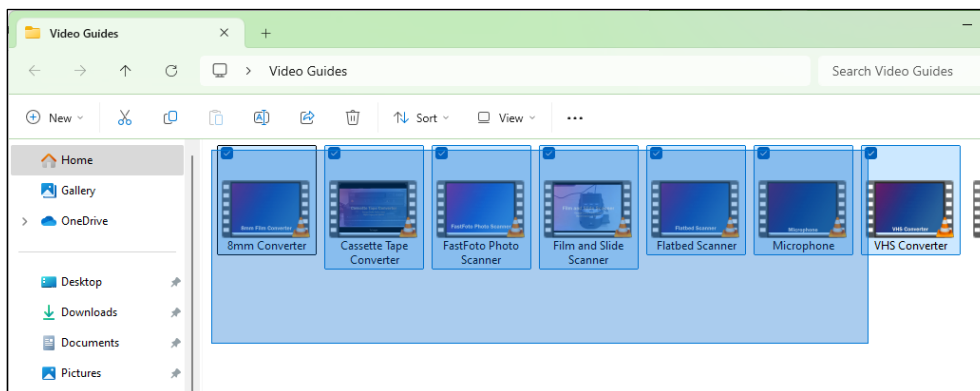

4. Click and hold the left mouse button while over the highlighted files. While still holding the left mouse button, move the mouse so it is over the USB drive on the left. When the computer says, “Copy to [USB Drive Name]” release the button and the files will start moving.

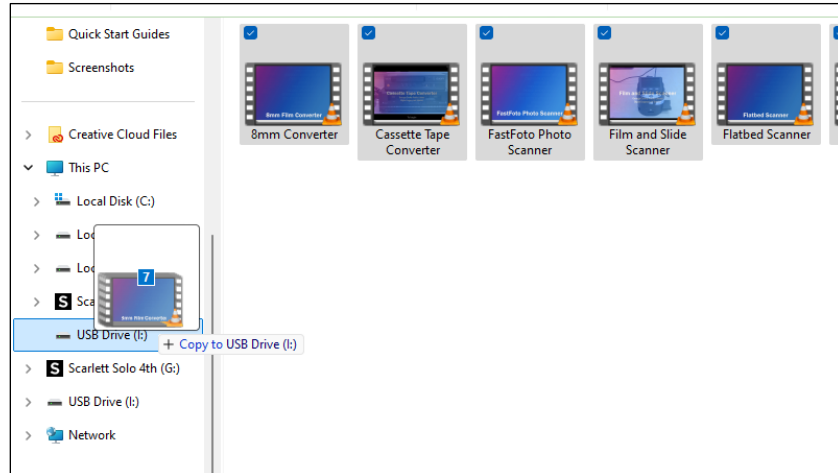

- a. If the files are large or there are a lot of them, this may take some time.

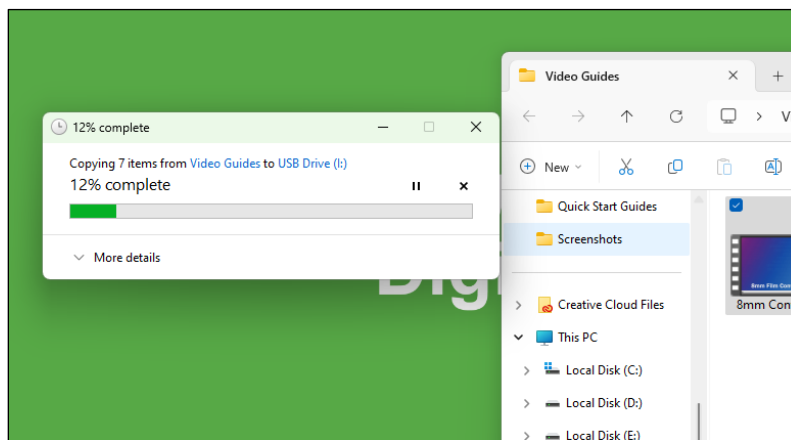

- b. If the computer says the files are too large, refer to Saving to a ZIP Folder in the Digital Legacy Lab binder.

5. Once your files are moved, right click the mouse button on the USB drive and choose Eject. Never remove the USB drive without ejecting it first as it may corrupt the files.

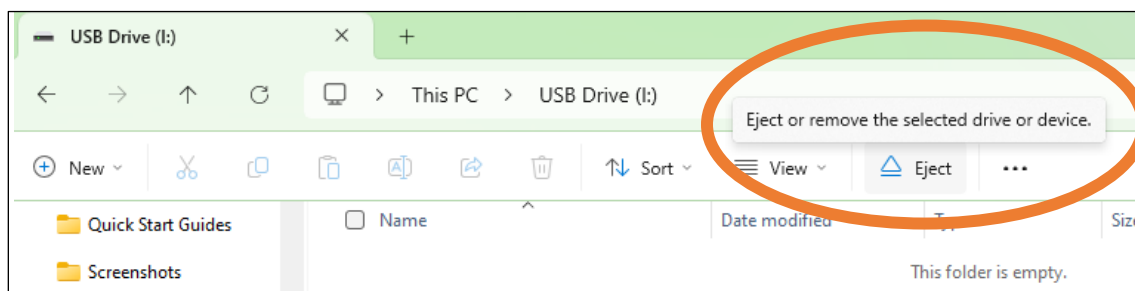

- a. A window will pop up in the bottom right corner of the screen that says “Safe To Remove Hardware.” Once you see this window, you may remove your USB drive.



Live Audio Recording Basics

The FocusRite Scarlett Solo 4th gen audio converter records in real time and can be used to record voices, devices, or instruments. Create commentary for videos, preserve oral history, or sing a song.

The Digital Legacy Lab offers the CM25 MkIII condenser microphone and SH-450 headphones to assist with audio recording and playback. You can also bring in your own electronic instruments and Hi-Z instrument cable to connect to the converter.

Table of Contents

Record Your Audio with Audacity..... 41
 Save Your Audio..... 45

Record Your Audio with Audacity

1. Make sure the microphone is plugged into **Input 2** on the back of the Scarlett Solo converter.
 - a. If using the SH-450 headphones, make sure they are plugged into the headphone output.
 - b. If recording an instrument such as a guitar or keyboard, plug in your instrument cable into **Input 1** on the front of the Scarlett Solo converter

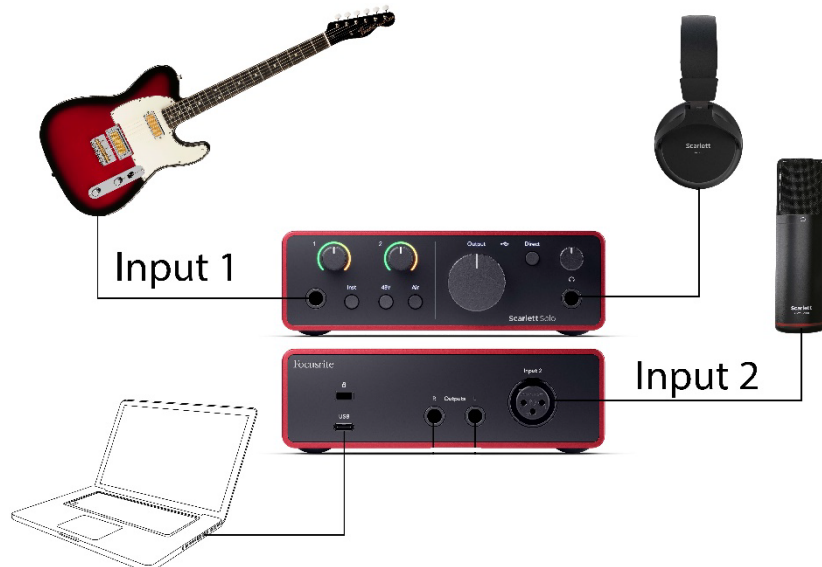

2. On the computer desktop, double-click on the **Audacity** icon. It looks like this:



3. Check the Audio Setup to make sure the microphone is chosen. Many devices are plugged into USB ports in the Digital Legacy Lab, this will make sure it records the sound.
 - a. Click **Audio Setup**

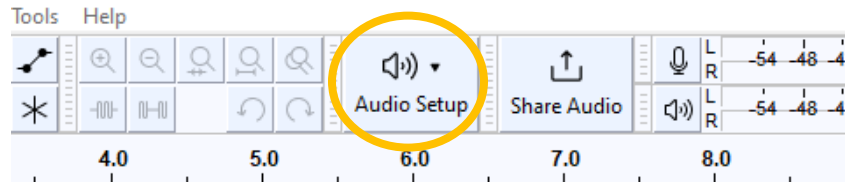

- b. In the dropdown menu, click **Audio Settings**.

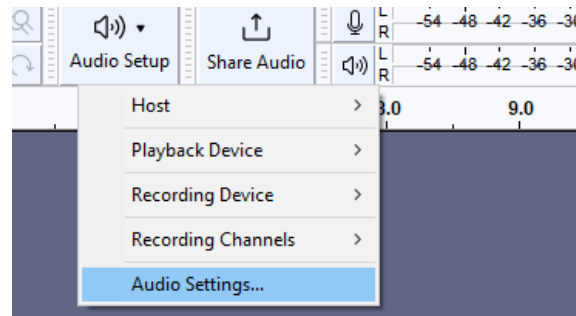

- c. **Playback** should be either the on-board Computer Speakers (to use your own headphones or the computer's speakers) or the Scarlett Solo Speakers (to use the Scarlett SH-450 headphones) depending on your preference to hear the sound.
 - d. **Recording** should be set to Device: Scarlett Solo and Channels: Stereo.

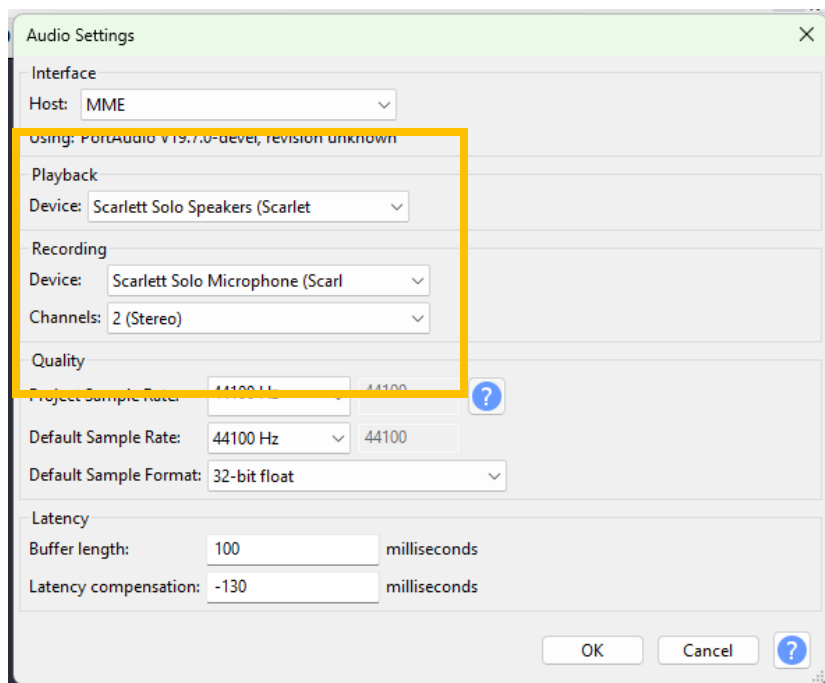

- e. Click **OK**
- 4. To start recording, click the red circle.

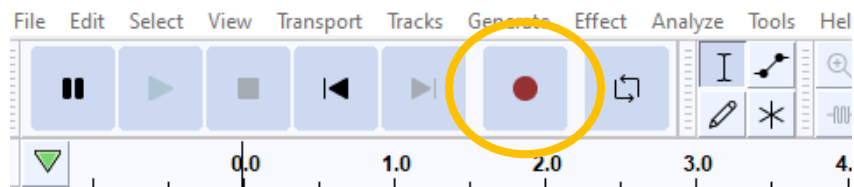

- 5. Record the audio.
 - a. When using the microphone, the audio will record in stereo, but only on the right side. This is normal.
 - b. Do not record in mono with the microphone. The audio will not be recorded.
- 6. When finished, press the black square.

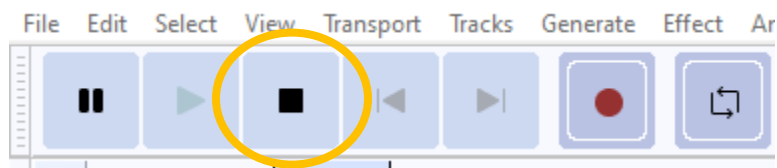

- 7. To replay the audio, press the green triangle.

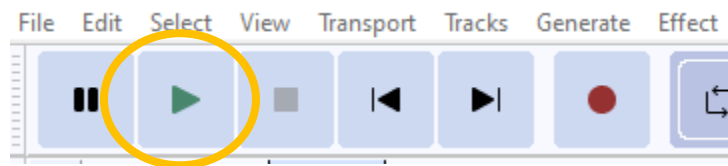

- 8. To trim the audio, click and drag to highlight the area you want to keep. Then press the Trim button.

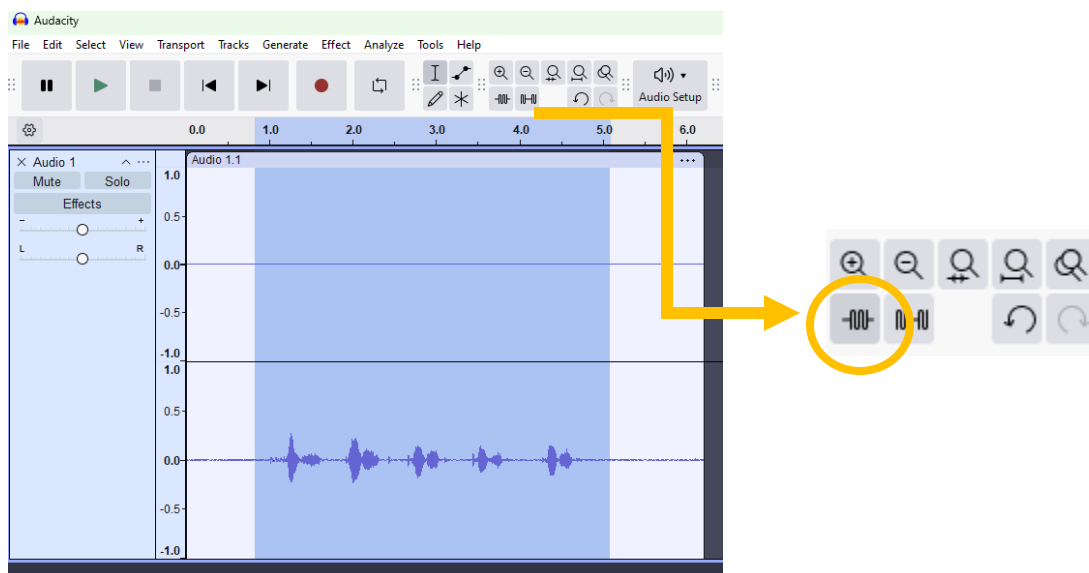

- To create a mono audio file (audio on both left and right sides), click and drag to highlight the area you want to keep, or press ctrl+A to select the whole file. Then click **Tracks**, then **Mix**, then **Mix Stereo Down to Mono**.

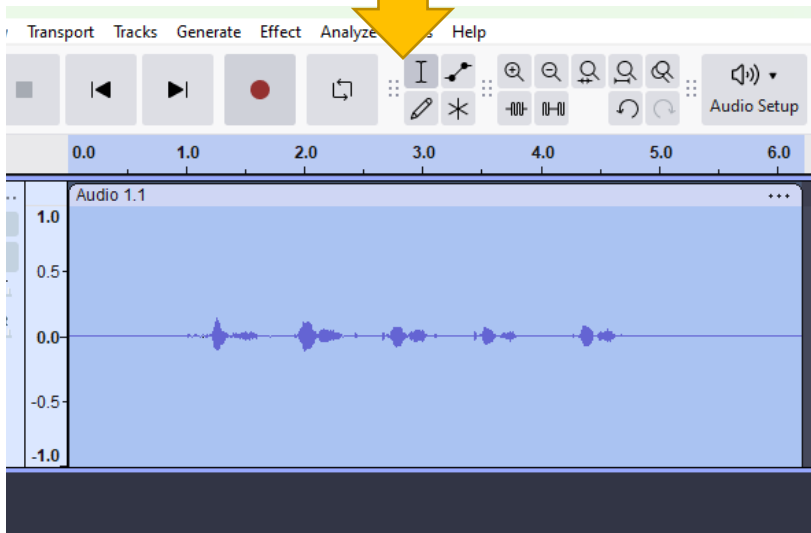
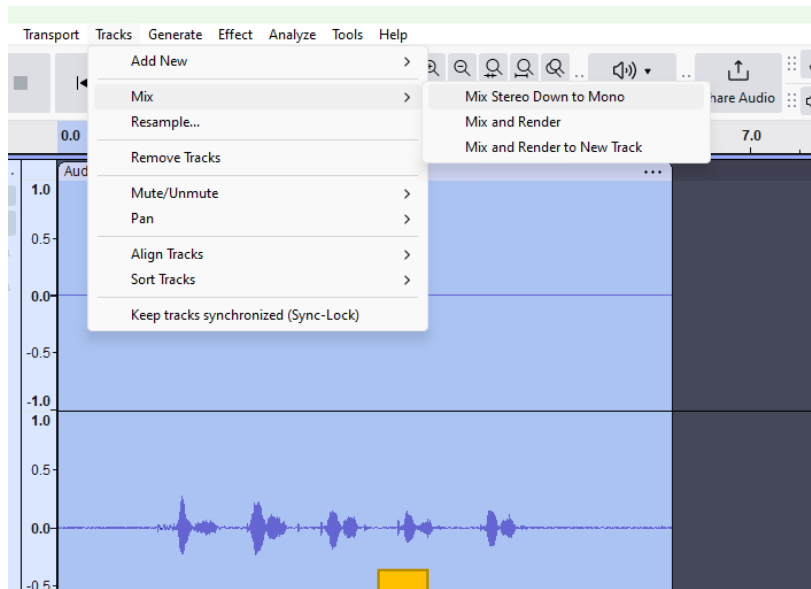

Save Your Audio

1. In Audacity, click File. Then select Export Audio.

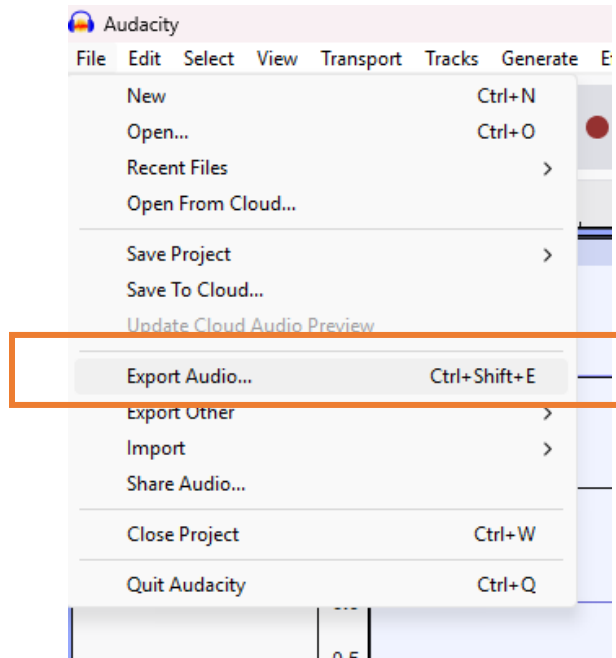

2. Title your track and select your format. You can also edit your metadata, or change where the file will be stored.
 - a. In most cases, you will be fine with an MP3 or WAV file.

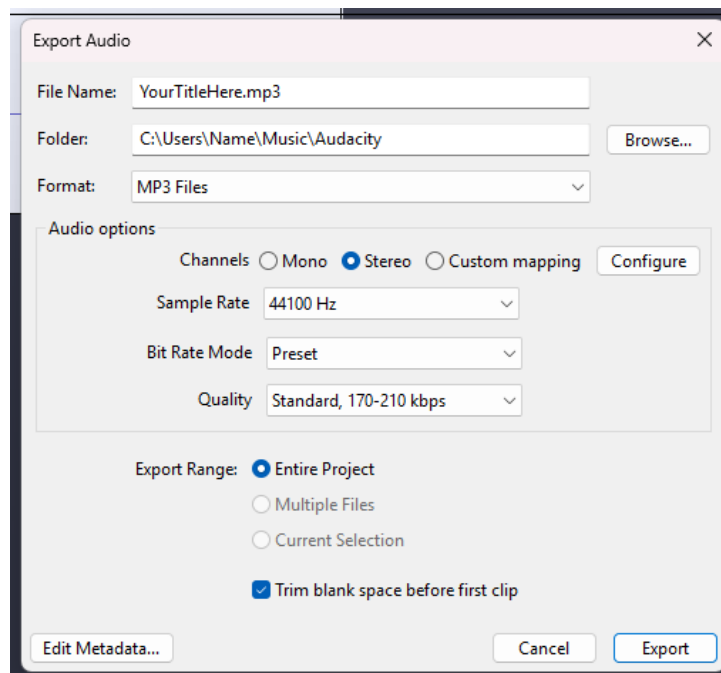

3. Save directly on to your USB drive by clicking **Browse** and then under Devices and drives, locate your USB drive. Note: it may not be called USB drive depending on your device.
 - a. Double click on the drive to **Open**.

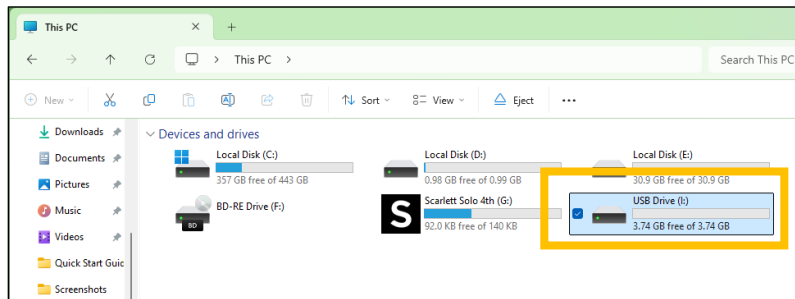

4. Change the name of the file to make it easy to recognize by typing on the keyboard. Click **Save**.
 - a. In this example, the file name changed from “untitled.mp3” to “Audio Example 2023”

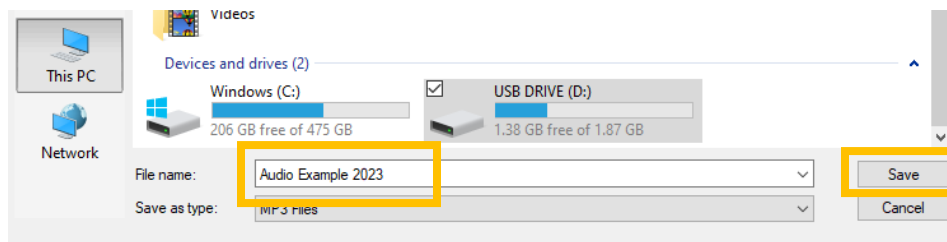

5. Add metadata if desired. This information is stored with the mp3 file. **This is optional.**

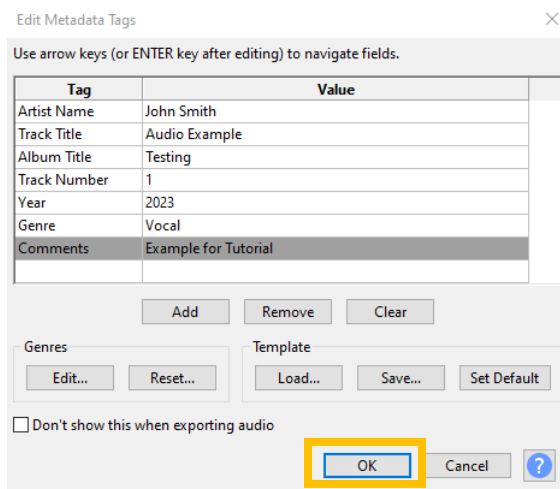
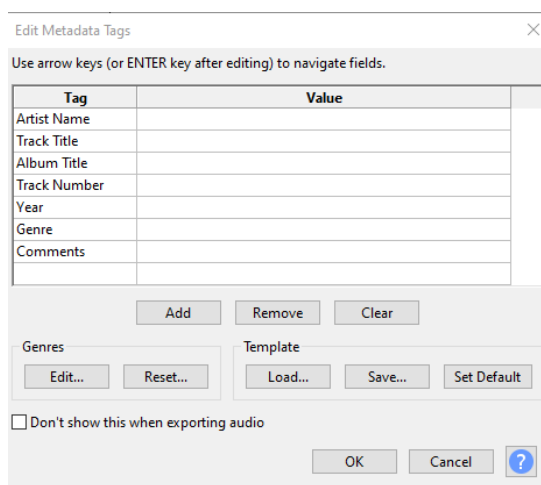

6. When you are ready to save your file, select **Export**. Your file is now saved.
7. Repeat these steps for any audio you create.

Slides and Negatives Scanner Tutorial

The Kodak Slide N Scan Digital Film Scanner converts your slides and negatives to digital images that you can store and preserve. The scanner supports 50mm slides and color and black & white film negatives (135, 110, and 126).

Scanning 8mm and Super8 film negatives is available upon request. Contact the Digitization Specialist to set up an appointment.

Table of Contents

Scanner Set Up.....	47	Capture.....	49
Preparing Media to Scan.....	48	Upload.....	50

Scanner Set Up

1. **Home/Preview:** The start page for using the scanner. Press to return home at any time.
2. **Power On/Off Button:** Press and hold to turn the device on and off
3. **OK/Scan:** Captures the image or confirms your selection
4. **Resolution/Delete:** Delete an image or adjust the resolution.
5. **Playback:** Displays images
6. **RGB/Forward and Brightness/Backward:** Navigates through your images forward or backward. Brightness and color are preset automatically, so additional adjustment is normally not needed.

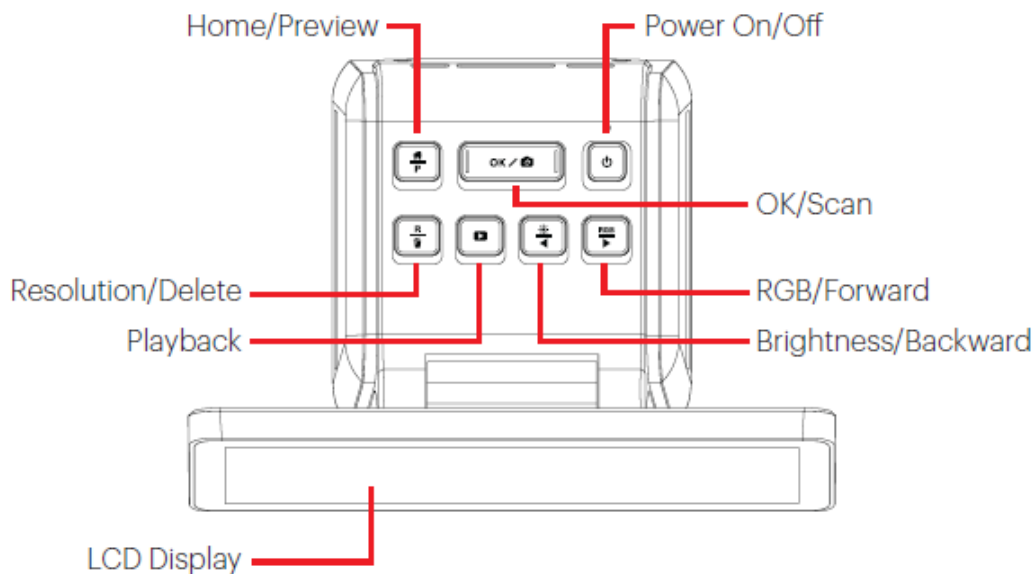

Preparing Media to Scan

1. Select the appropriate slide holder and adapter needed for your slides or negatives.
 - a. Each adapter tray and insert is clearly marked with the type of film it adapts.

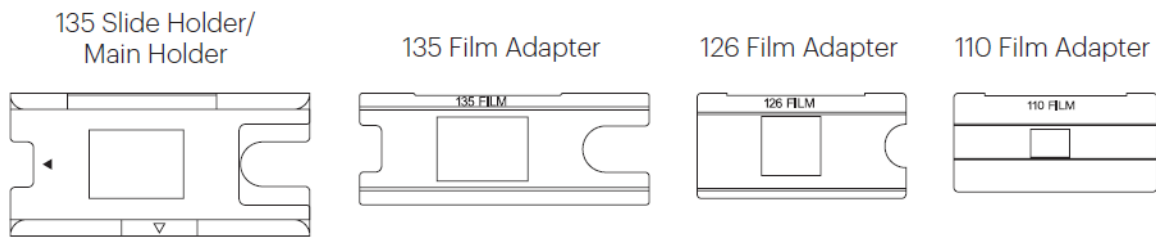

2. To load slides:
 - a. Flip up the top cover of the 135 Slide Holder/Main Holder
 - b. Place the slide into the holder. Line up the slide with the opening.
 - c. Snap the holder closed.
3. To load negatives:
 - a. Flip up the top cover of the 135 Slide Holder/Main Holder
 - b. Select the appropriate adapter for your film (135 film adapter for 135 film, etc.)
 - c. Place the adapter into the 135 Slide Holder/Main Holder. Make sure that the four pins of the adapter are inserted into the four holes of the holder.
 - d. Place the negatives into the holder. Line up the negatives with the opening.

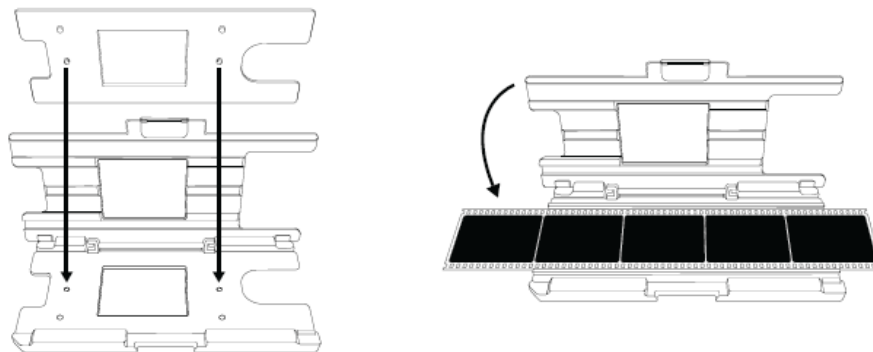

- e. Snap the holder closed. It should be completely flat. If it does not close properly, do not force it shut. Reposition the adapter and try again.

4. Place the holder with your slide or film into the adapter.

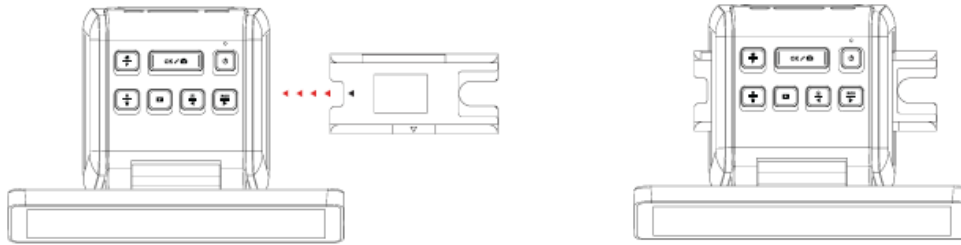

Capture

1. Turn on the scanner by pressing the Power On/Off Button.
2. Select Film Type on the home page and press OK/Scan to confirm.



3. Use the arrow buttons to choose your type of film (50mm slide, color negative, or b&w negative). Press OK/Scan button to select.

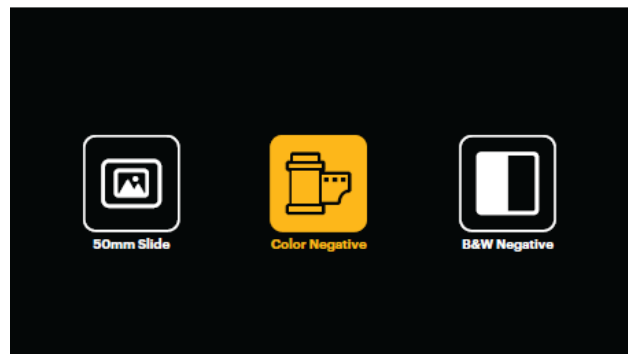

4. Once you have selected the film type, a submenu for film size will appear on the screen. Use the arrow buttons to choose your film size (110, 126, or 135), and press OK/Scan button to select.

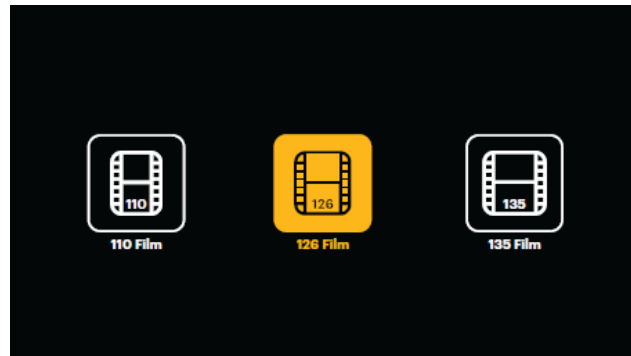

5. Confirm that the slide or negative is centered on the screen.
6. Press the OK/Scan button to scan. The image will automatically save.
7. Feed more slides into the scanner or shift the film until the next image appears.
8. Continue steps 3 and 4 until all images have been scanned.

Upload

To save your digitized images to your USB drive, you must upload the files from the scanner to the computer.

1. Go to the Home Menu on the slide scanner and press the right arrow key until it selects “USB Upload.”
 - a. Press the OK/Scan button
2. Wait for the scanner to connect to the computer. This may take a few seconds. When connecting, the computer will recognize the scanner as an external device.
3. Go to This PC and locate the new drive that appeared. The USB drive may have a different name, depending on what is plugged into the computer.

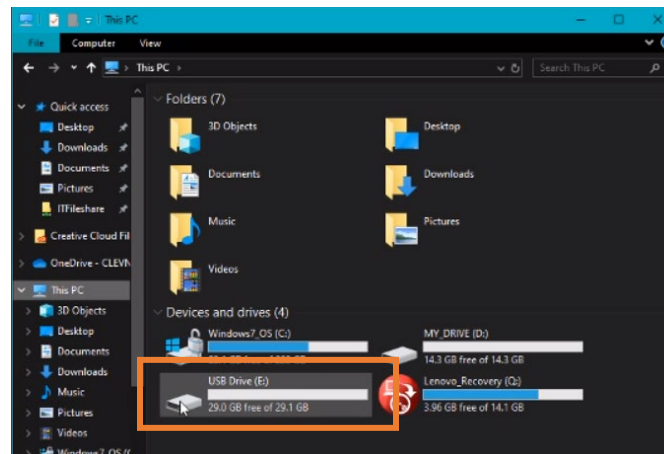

4. Click the folders until you find your images.
5. Highlight the images you would like to transfer.
 - a. Click and drag the files to your USB drive.
 - b. Check that they are on your USB drive.

FILES DO NOT DELETE AUTOMATICALLY. Please be sure to delete your files before leaving the Digital Legacy Lab.

To delete all files at once:

1. Press the Playback button to enter Playback mode:



2. Press the Resolution/Delete button twice to enter Delete All mode



3. Press the Right Arrow/RGB once to highlight YES in yellow, and press the OK button.



To delete individual files:

1. Press the Playback button to enter Playback mode:



2. Press the Resolution/Delete button twice to enter Delete All mode



3. Press the Right Arrow/RGB once to highlight YES in yellow, and press the OK button.

VHS and DVD Conversion Tutorial

The Digital Legacy Lab can convert VHS, VHS-C, and DVDs using the UCEC All-in-One USB 2.0 Video Capture converter. Use the adapter to connect to the Sony SLV-D350P VCR and DVD Player.

Table of Contents

Recording a VHS or DVD.....	52	Troubleshooting.....	60
Save Your Video Files.....	54		

Recording a VHS or DVD

1. Make sure the DVD/VHS player is plugged into the All-in-One converter and turned on.



- a. This is the converter. Connect each plug to the matching plug on the cord attached to the DVD/VHS player.
 - i. Red to red, yellow to yellow, and white to white.
 - ii. The other end (USB connection) should be plugged into the computer or USB strip.
2. If the VHS/DVD player starts playing, press STOP for now.
 3. Double-click the **Honestech VHS to DVD 3.0** icon on the desktop.



4. If prompted, enter the product key for the software. If not prompted, skip to the next step.

- a. The product key is located on the Honestech CD case in the Digital Legacy Lab storage bin. It is also located on the inside back cover of the DLL binder.
5. The Honestech window will open.
6. Click **Option**.

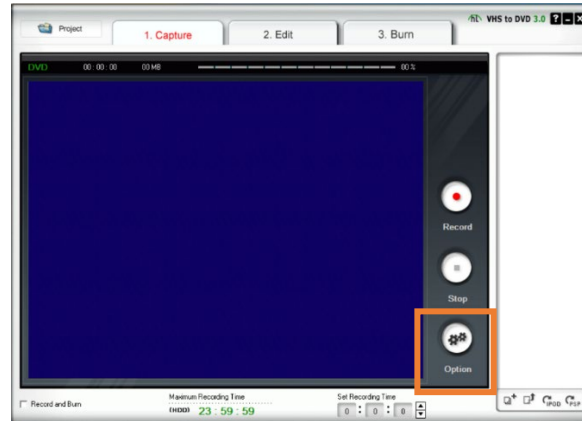

- a. Make sure the AV TO USB2.0 is selected for video.
- b. Make sure the audio is Microphone (2-AV TO USB2.0).
- c. Click **OK**.

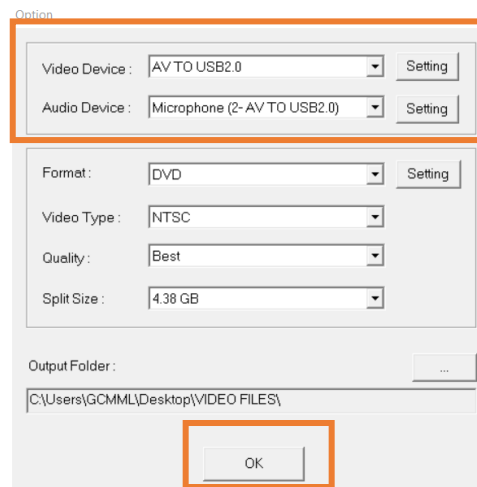

7. Press **Record** on the Honestech software and then press **Play** on the VHS player or DVD player.
 - a. The tape will start to play and the software will record.
 - b. You should see the video on the screen and hear the audio.

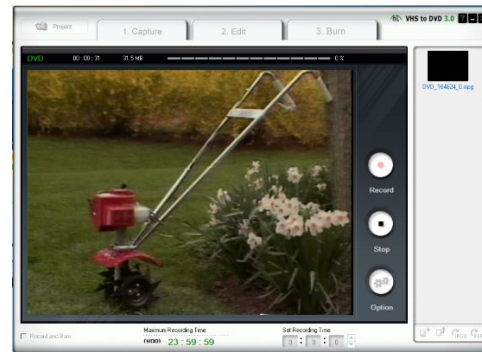
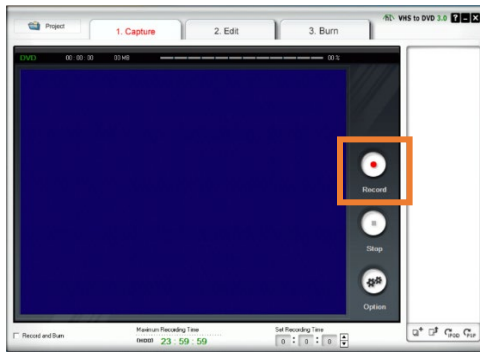

8. When finished, press **Stop** on VHS and DVD player and then **Stop** in the Honestech software.

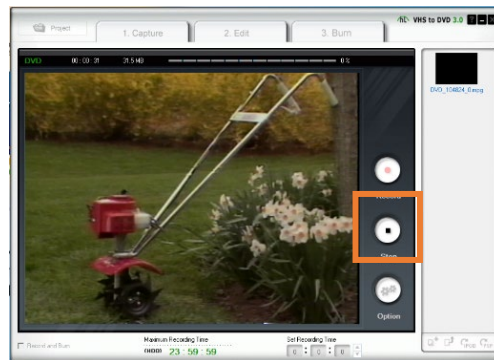

9. Rewind your VHS tape and eject it from the VHS player. Eject the DVD from the player.
10. Insert a new VHS or DVD to record another video.
11. When finished, save your files to a USB drive, or burn them to a DVD.

Save Your Video Files

Geauga County Public Library recommends saving your files to a USB drive (also known as a flash drive or memory stick) with at least 8GB of storage data. USB drives come in many sizes, so choose the size best for your projects and budget.

1. Close or minimize the Honestech window. You do not need to save the project.

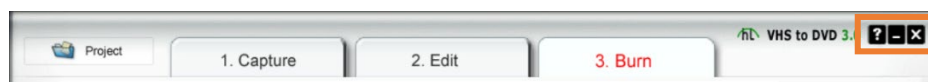

2. Locate your files. Files are located in the Documents folder in the File Explorer.
 - a. Click on File Explorer in the taskbar.
 - b. Click on Documents.
 - c. Double click on the VHS to DVD folder.



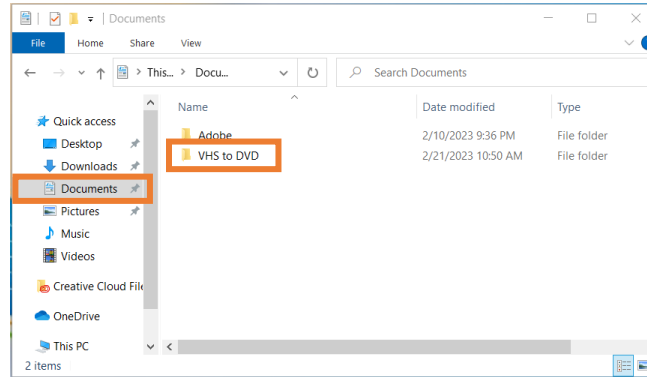

- d. If you changed the save location in the Honestech Options, locate that folder instead.
3. Highlight the files you want to save by clicking and dragging the cursor over them.
4. Click on the highlighted area and drag your files to your USB drive on the left.
 - a. If the files are large, try saving one at a time.

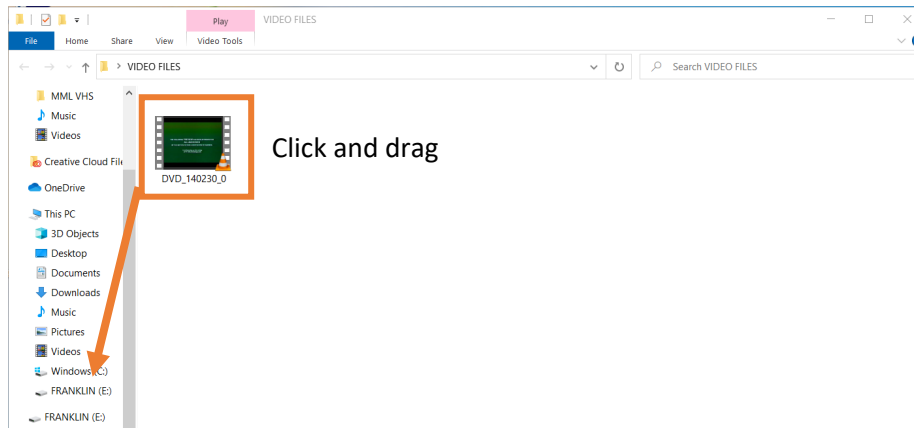

File Too Large to Save

If an error message appears that says the file is too large to transfer to your USB drive, but there is enough space on the drive for your file, follow these steps to save your files in a zip file.

For example, you have an 8GB USB drive and a 5GB video, but the computer says it cannot save the file because it is too big.

1. Open the location of the video files in File Explorer.
 - a. Open the VHS to DVD folder in the Documents folder.

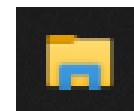

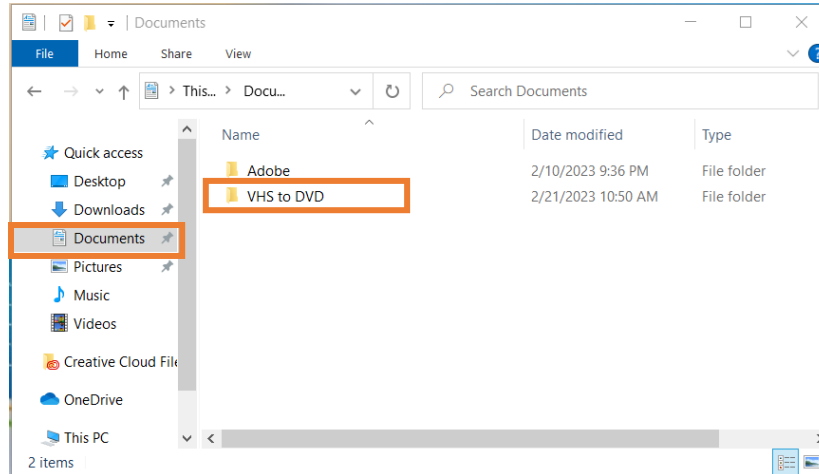

2. Click **Documents** and then **New > New Folder** to create a new folder.

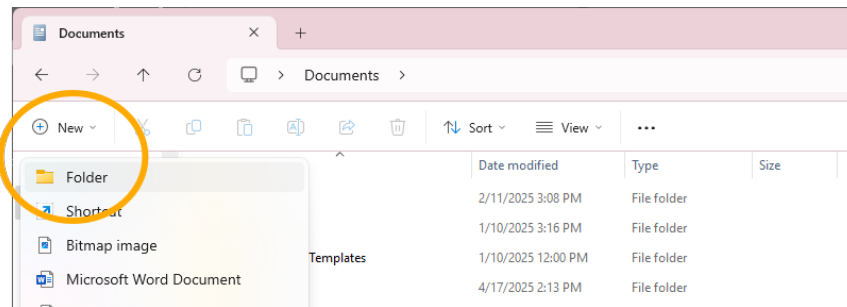

3. Rename the new folder

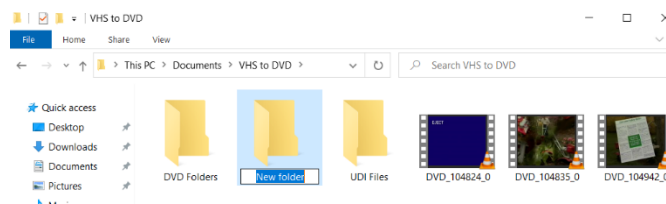

4. Click and drag around the files you want to save to your USB drive. This will highlight them.

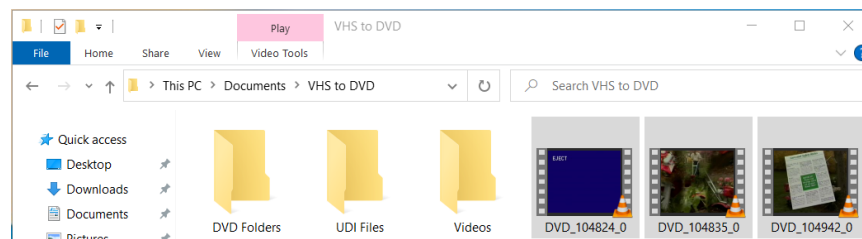

5. Click on the videos and drag them into the new folder.

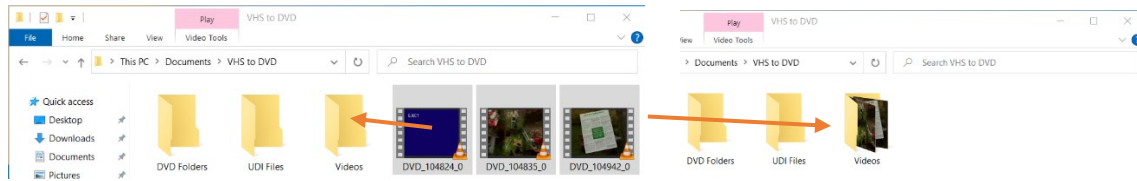

6. Right-click on the folder. A menu will appear.
 - a. Select **Compress to > Zip file**
 - b. Then click **Add to "Videos.zip"**
 - i. **NOTE:** it will not say "Videos" unless that was the name of the folder you created. It will say your folder name.
7. The computer will make a zipped folder.

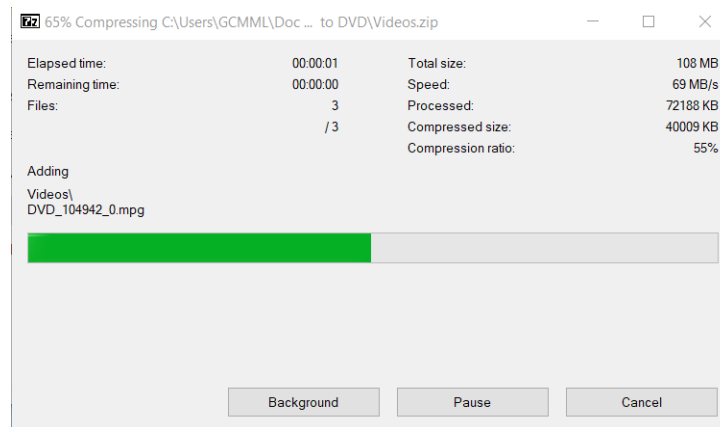

8. Click and drag and new zipped folder to your USB drive.
 - a. A zipped folder has a zipper on it:



Burn to a DVD

There are multiple ways to burn a DVD. Here are the directions to burn a DVD in the Honestech software.

1. After recording the video(s) you want to burn to a DVD, click the **Burn** tab.
2. Click and drag the files on the right side of the screen to the middle of the software.



3. This will create a default menu that you can edit.
 - a. Double-click on the title ("My Title") to type in a new title



- b. Double-click on each file name under each video to change the name of each individual video and organize the videos.

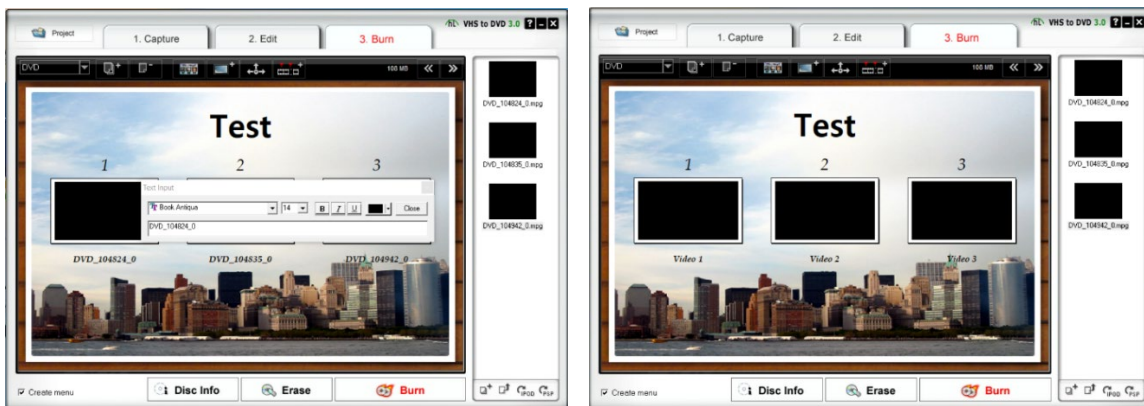

- c. If you do not want an automatic menu, uncheck the box next to "Create menu." The screen will change to this.

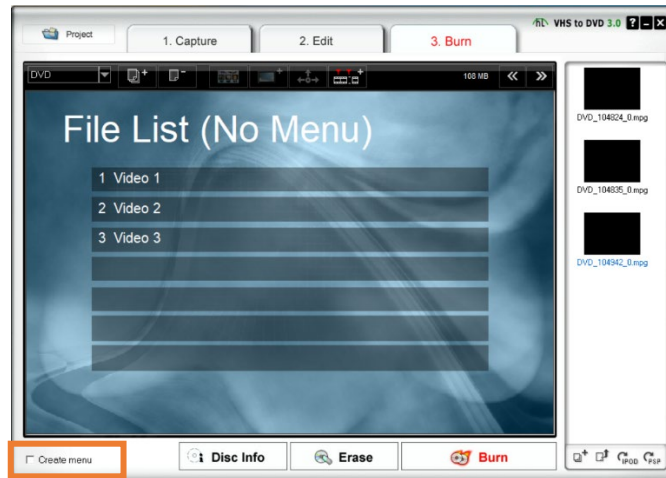

4. Insert the blank DVD into the computer CD/DVD drive.
 - a. Wait until the computer recognizes the blank DVD. This may take some time.
 - b. If the DVD is not recognized, try ejecting and re-inserting the DVD.
5. When ready, click **Burn** in the Honestech software. The videos will be burned to the DVD and will be playable in a DVD player.

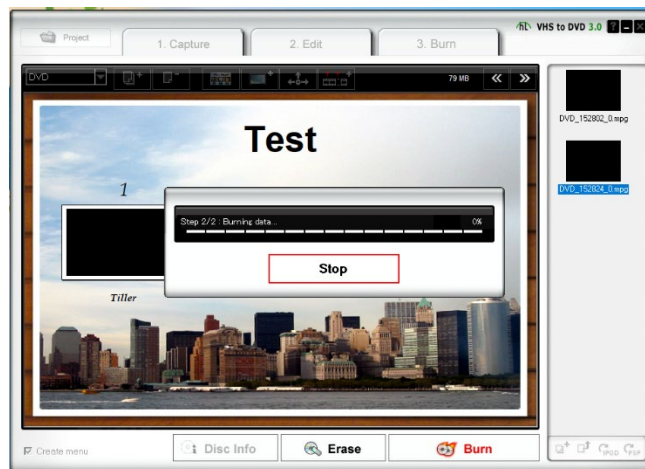

6. Eject your DVD from the computer.

VHS/DVD Converter Troubleshooting

Problem	Cause	Solution
The device is playing but there is no video or audio playing on the PC	The All-in-One converter is not correctly plugged into the device.	Plug each cord into its color-corresponding plug on the device. Make sure that the USB port is plugged in.
Cannot hear the recordings once saved and trying to play them on the computer	Computer audio output not set correctly.	Access the Settings > System > Sound . Under Output , select the device you are using to listen.
Audio is playing, but no video is playing on the Honestech software	The Honestech software options are not set correctly.	In Honestech, click Option . Make sure "AV TO USB 2.0" is selected for Video Device. Make sure "AV to USB 2.0" is selected for Audio Device. Select OK.
The AV to USB2.0 option is greyed out in the Honestech software	Computer volume mixer settings not set correctly	Close Honestech. Access the Settings > System > Sound . Under Advanced Options , select Volume Mixer . In the Input device dropdown menu, select AV to USB2.0 . Restart Honestech.

Vinyl Record Converter Tutorial

The Audio-Technica AP-LP120XBT-USB turntable can convert 33 1/3 and 45rpm vinyl records. Records are digitized in real time.

78rpm conversion is available upon request. Please contact the Digitization Specialist to set up an appointment.

Table of Contents

Recording Audio.....	61	Burn to a CD.....	65
Save Your New Music File.....	63	Troubleshooting.....	68

Recording Vinyl Audio

1. Turn the power dial to ON. The power dial and rpm speed buttons will light up.
2. Gently remove the cartridge protector.

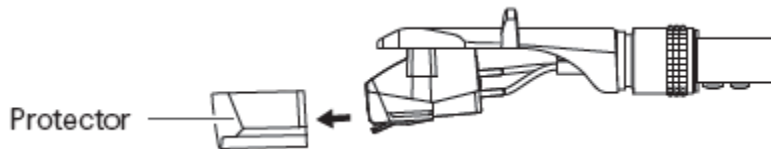

3. Open the Audacity software on the DLL desktop. The Audacity icon looks like this:

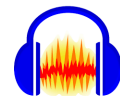

4. Press the Record button on the software. The Record button is a red circle.

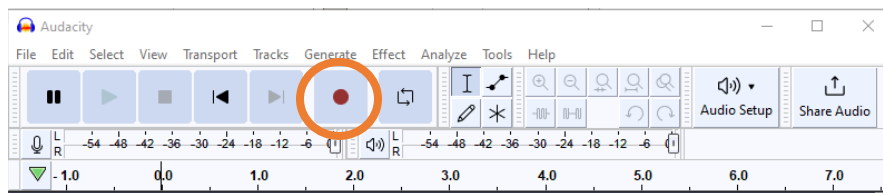

5. Place the vinyl record on the platter. Press the Start button.

- a. Press 33 for 3 1/3 rpm or 45 for 45 rpm. The record will say what type it is on the label.

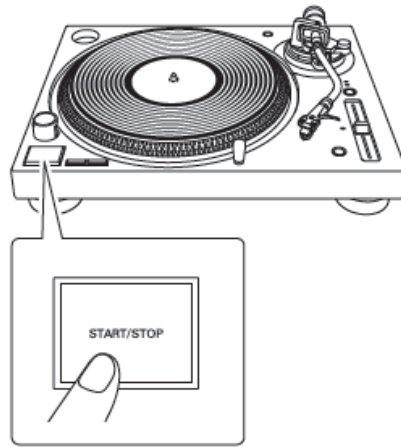

- b. If converting a 45 rpm record, attach the 45 rpm adaptor beneath the record. The adaptor is located in the top left of the turntable.

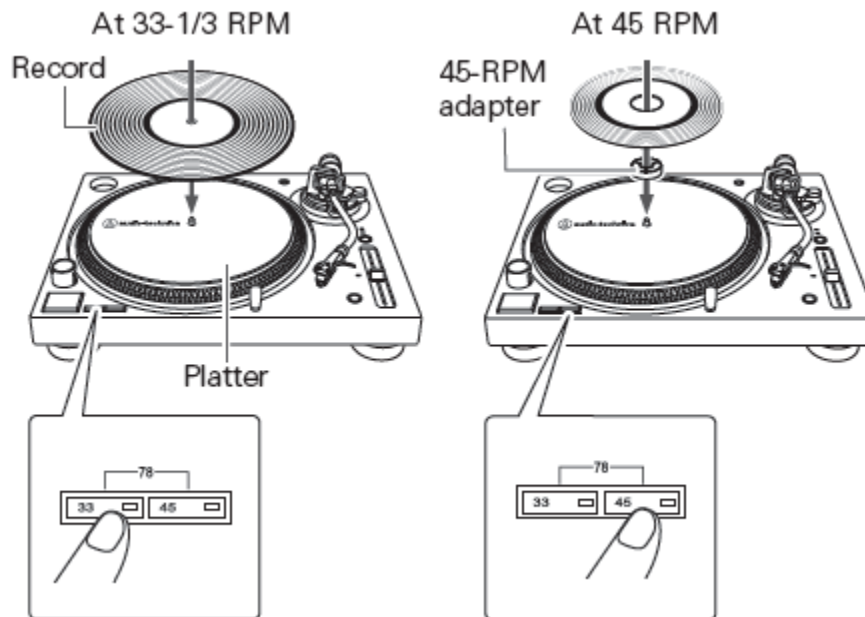

6. Place the needle on the outside edge of the record as it spins.
 - a. The record starts to play.

7. Audacity will begin recording your record.

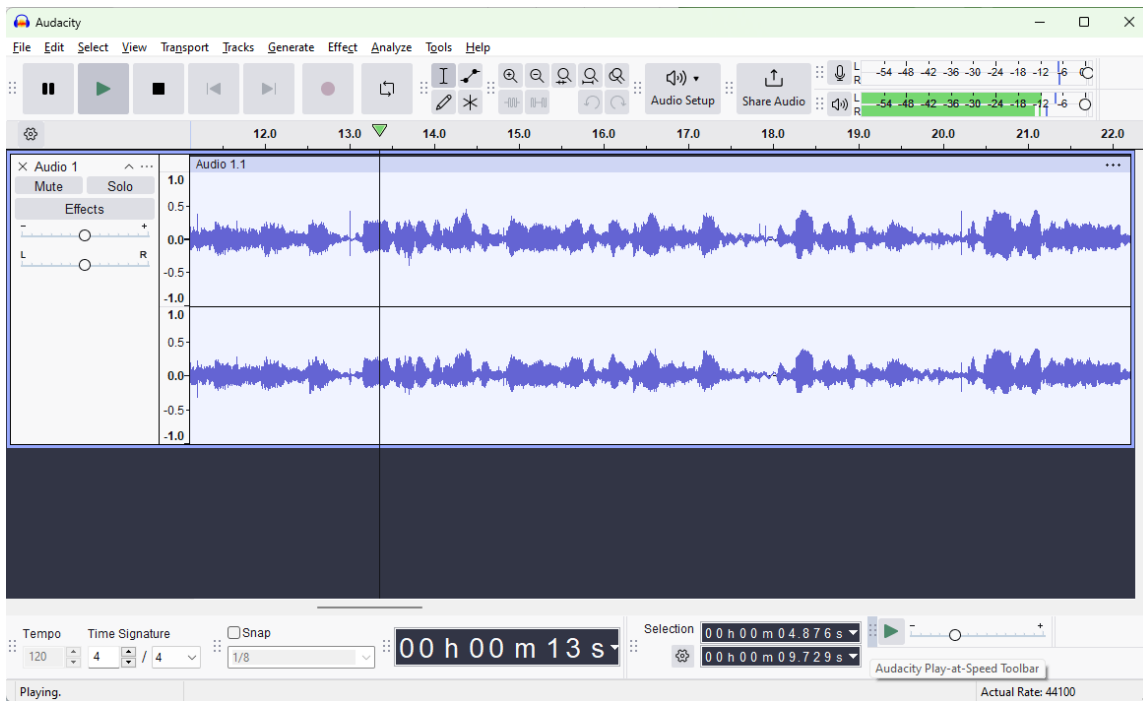

- a. If you can't hear the record playing as it records, make sure the Software Playthrough is on.
 - i. Click Transport → Transport Options → Enable audible input monitoring
 - ii. There should be a checkmark next to "Enable audible input monitoring".
If there is not, you won't hear the sound as it records.
8. When the record stops, press the Stop button on Audacity. The Stop button is a black square.

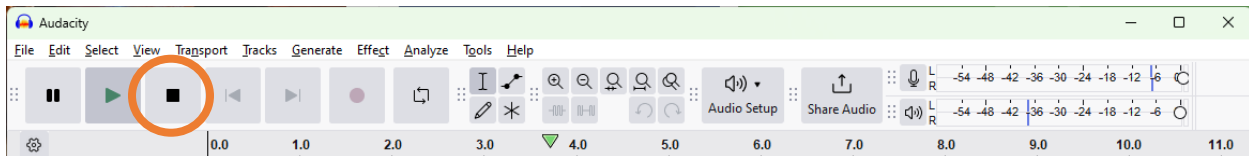

9. Once you are finished recording, replace the cartridge cover.

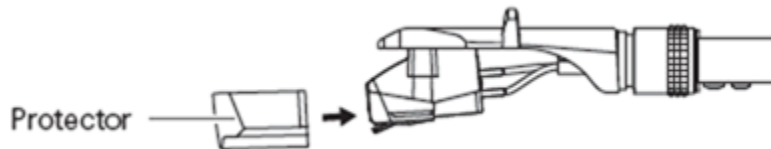

Save Your New Music File

1. In Audacity, click File. Then select Export Audio.

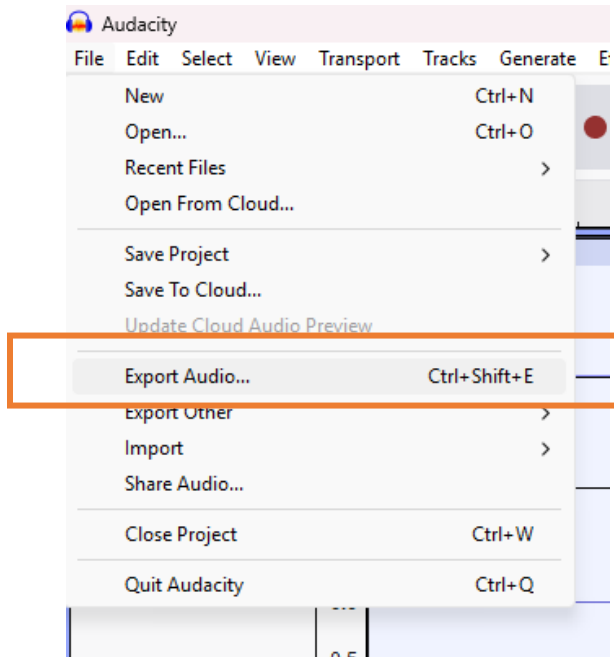

2. Title your track and select your format. You can also edit your metadata, or change where the file will be stored. When finished, press Export.
 - a. In most cases, you will be fine with an MP3 or WAV file.
 - b. Save your file to your USB drive by selecting **Browse**, then selecting your drive.

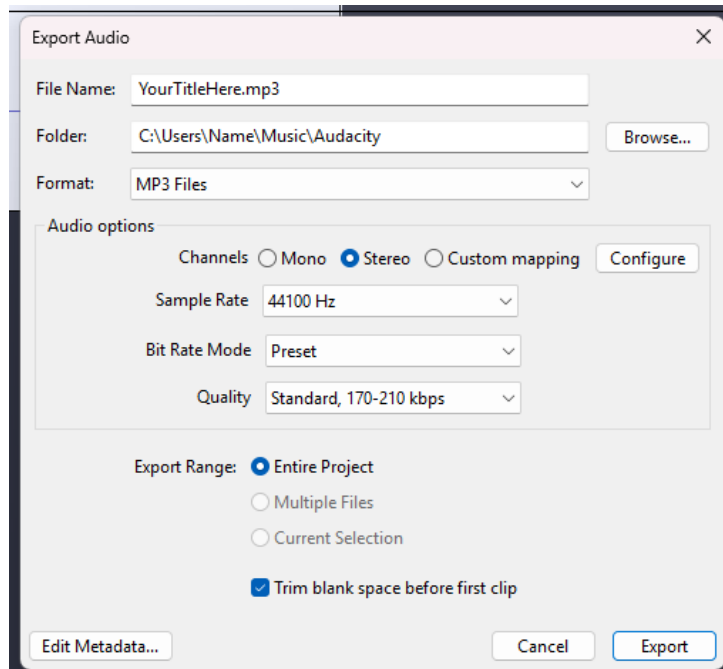

Burn to a CD

1. Insert the blank CD into the computer using the CD/DVD drive.



2. Left-click and drag to highlight all the files you want to burn to the CD.

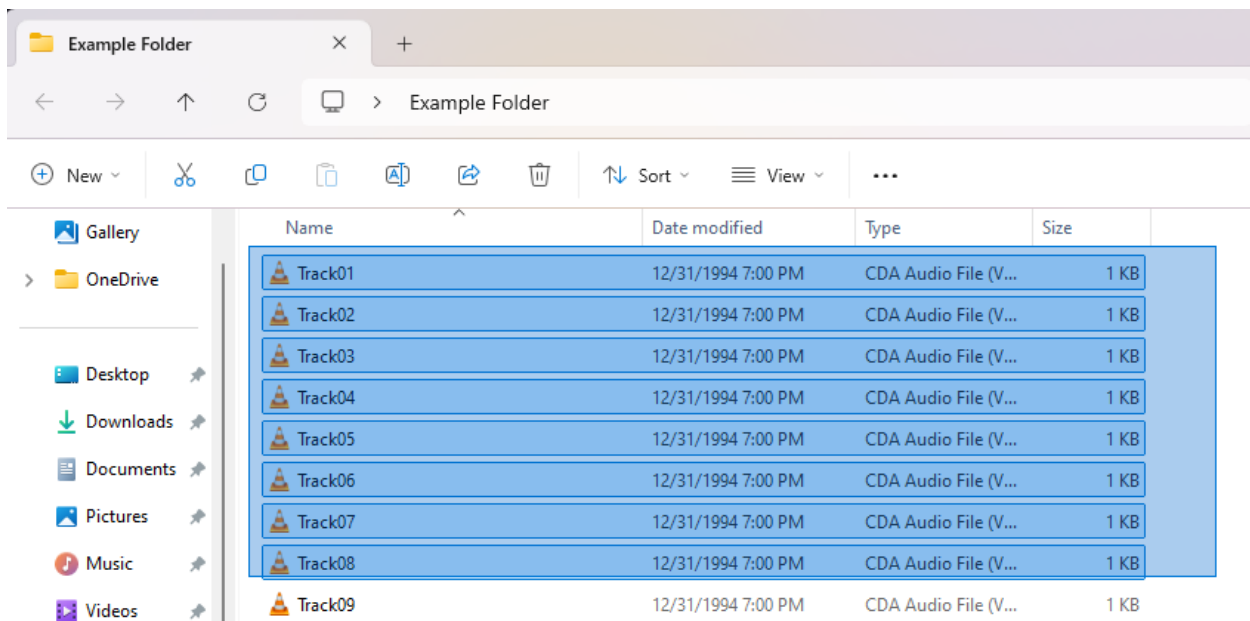

3. Click on the three-dots icon (. . .) in the top File Explorer menu.

4. Select **Burn to disc**

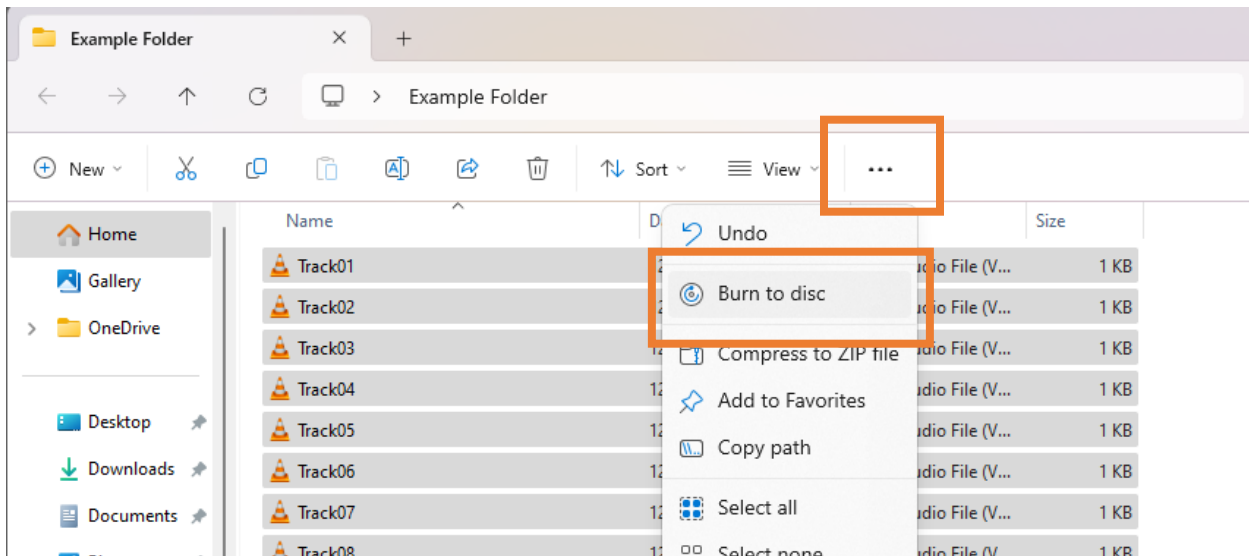

5. In the next window, select **With a CD/DVD player**. Click **Next**.
 - a. You can also name your disc in this window.

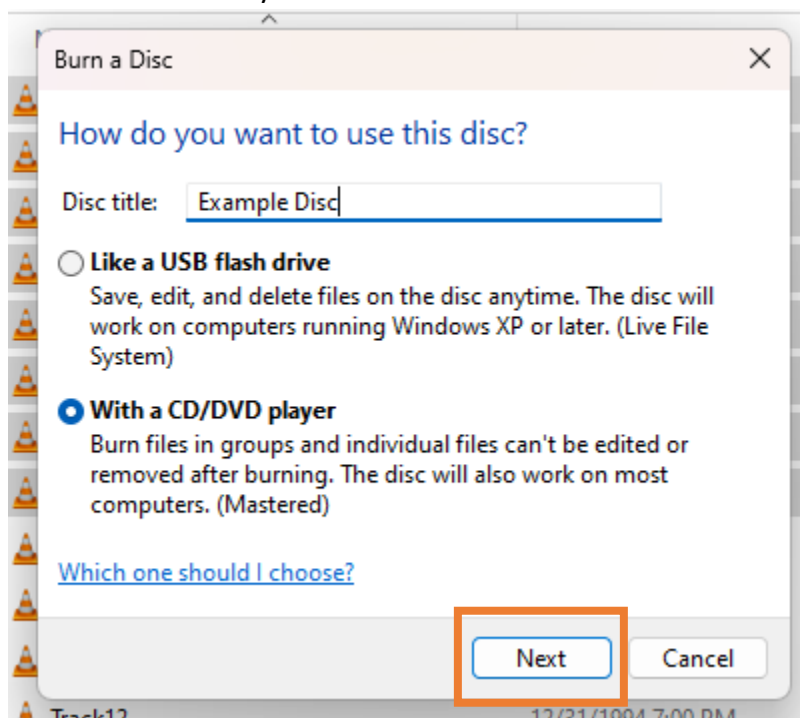

6. The next window that opens will be the CD. Click on the three-dots icon (. . .)

7. Click **Finish burning**.

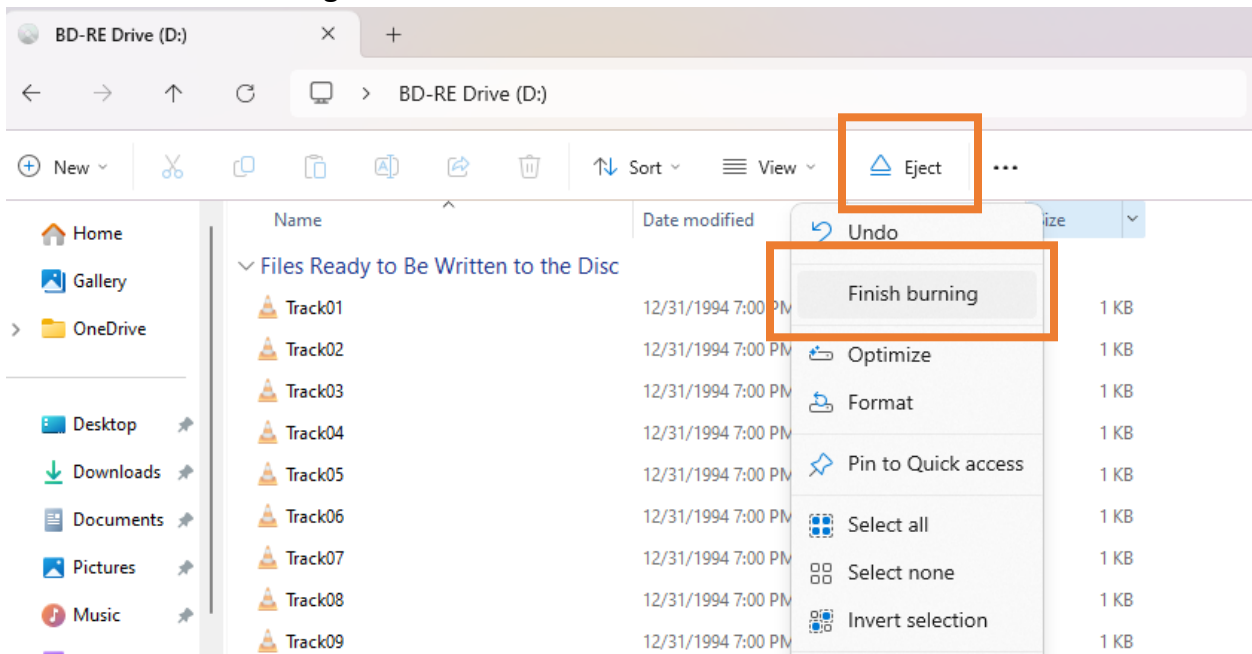

8. Click **Next**.

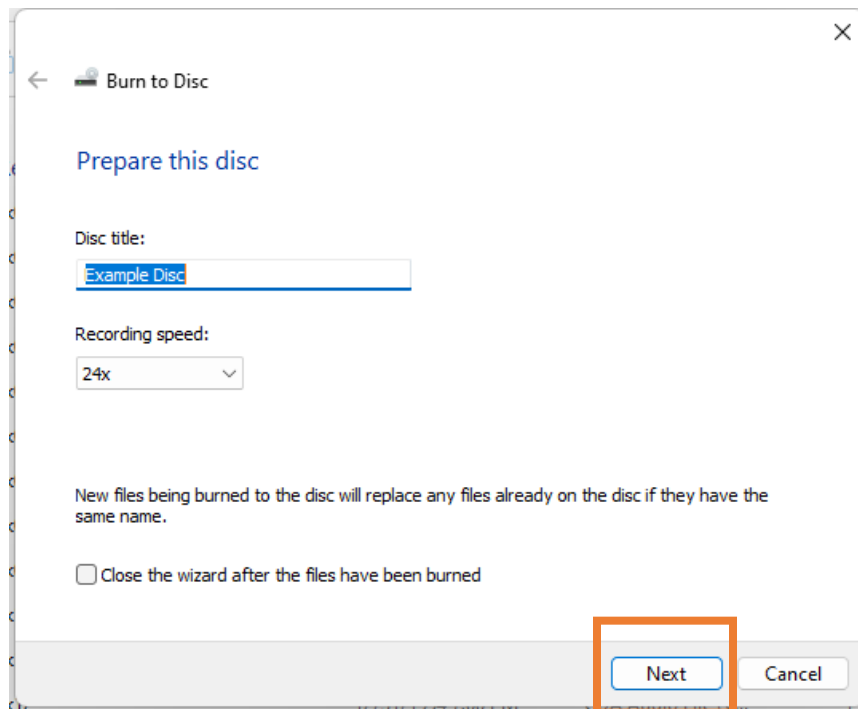

9. Once the CD has finished burning, the CD should automatically eject from the drive. If it does not, select **Eject** in the File Explorer menu.

Troubleshooting Issues with the Vinyl Recorder

Problem	Cause	Solution
Recording sounds loud and distorted	The gain level is too high	Option 1: Slide the gain slider next to the levels.
Recording is barely audible	The gain level is too low	Option 2: Turn the gain knob on the cassette player.
Cannot hear the recordings once transferred and trying to play them on the computer	Computer audio output not set correctly.	Access the Settings > System > Sound . Under Output , select the device you are using to listen.
While the USB device is connected, can't listen to any music from the computer		
Audacity is not registering any audio recording, but the record is playing.	Audio input not set correctly	Click the Audio Settings dropdown menu. Select Vinyl Recorder .
Recordings are mono instead of stereo	Recording input properties not set to "stereo"	<p>May need to manually specify "stereo."</p> <p>In Audacity:</p> <p>Select Audio Setup > Recording Channels > 2 (Stereo)</p> <p>If Audacity is set to "stereo" but recording is still "mono":</p> <ol style="list-style-type: none"> Go to Settings, then select System, then Sound. Click the Input tab and highlight the Microphone input Vinyl Recorder (USB Audio Codec). Click on Properties to bring up the input settings. Click on the Advanced tab and select 2 channel, 16 bit, 44100 Hz (CD quality) in the Default Format pull-down menu. Click Apply to accept the settings.
The sound from the USB device's audio outputs is distorted or full of static	Line/phono level switch may not be set properly.	Check the line/phono switch on the vinyl record player and make sure it is set to the appropriate level for the inputs connected.

Saving to USB Drives and External Hard Drives

Geauga County Public Library recommends saving to a USB drive (also known as a flash drive or a memory stick). The library recommends saving to a USB drive as it is easier, faster, can hold more files, and the most current storage device.

The library recommends at least **8GB of storage data**, but USB drives come in multiple sizes. Choose the best size for your projects and budget: larger media like videos will take more room, smaller media like documents and jpg images will take less. Refer to Storage Recommendations in the Digital Legacy Lab binder for data storage size suggestions.

The Digital Legacy Lab uses Windows PCs. Be sure to bring drives that are formatted to work with Windows. If your USB drive is used with a Mac computer, it may not work properly.

The best practice is to save your files as you digitize and not wait until the end to save everything if you can avoid it. This will make saving go faster.

To save to a USB drive:

1. Plug in your USB drive into a USB port on your computer. The USB ports on the Digital Legacy Lab PCs are located on the right side of the screen.



2. Locate the folder on the desktop where your files are stored.
 - a. You can also open This PC and check the Documents or Photos folders if you cannot locate them. The library has set up the save locations, but sometimes these can change depending on the software. You can check where they are saved in the software.

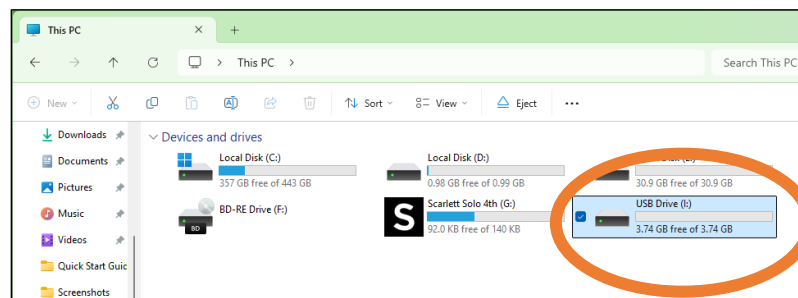

3. Highlight the files you want to save by clicking and dragging around the files with the left mouse button. You can also move them one at a time.

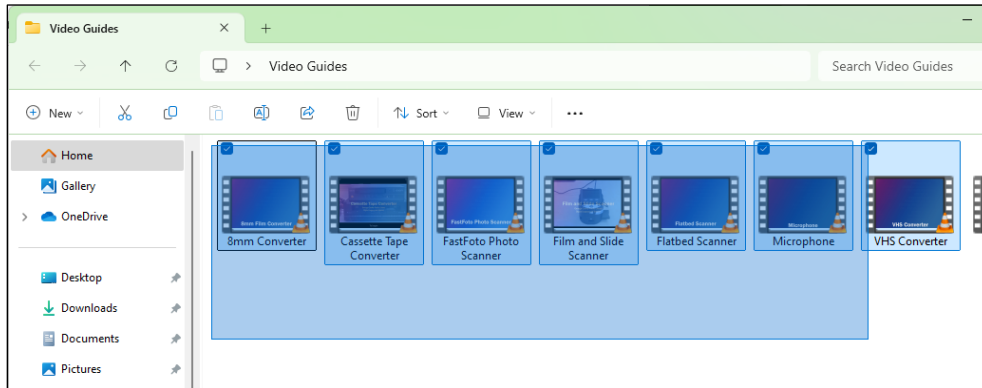

4. Click and hold the left mouse button while over the highlighted files. While still holding the left mouse button, move the mouse so it is over the USB drive on the left. When the computer says, "Copy to [USB Drive Name]" release the button and the files will start moving.

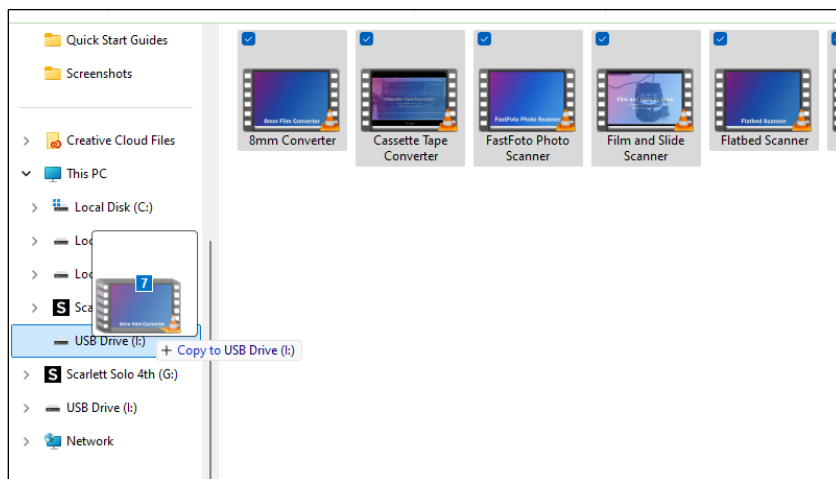

- a. If the files are large or there are a lot of them, this may take some time.

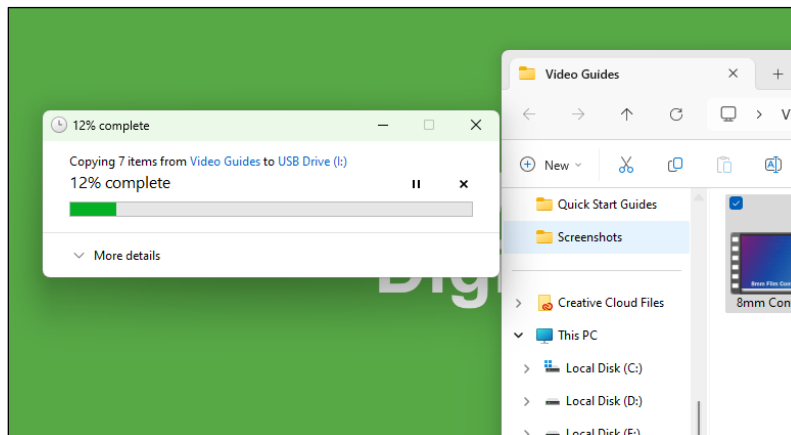

- b. If the computer says the files are too large, refer to Saving to a ZIP Folder in the Digital Legacy Lab binder.
- 5. Once your files are moved, eject the drive. Never remove the USB drive without ejecting it first as it may corrupt the files.
 - a. Option 1: Select Eject from the USB folder toolbar.

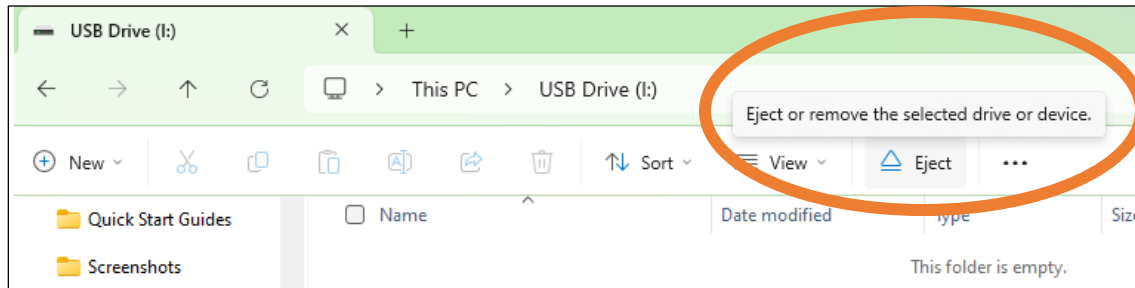

- b. Option 2: Select Eject from the taskbar.
 - i. Click the arrow in the bottom right corner of the taskbar to Show hidden icons.
 - ii. Select the Safely Remove Hardware and Eject Media icon. It looks like a USB drive with a check mark.

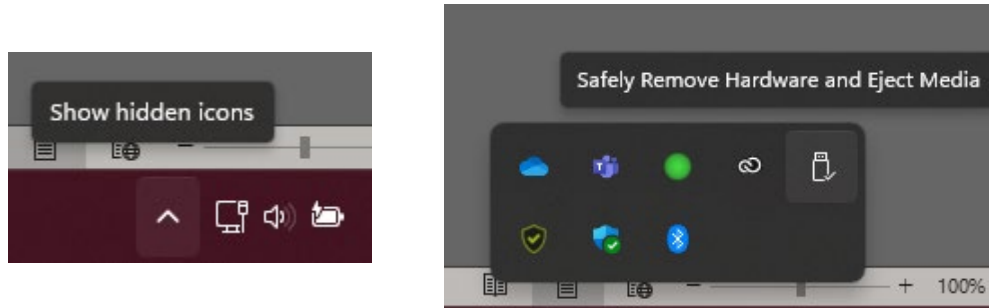

- iii. Select Eject USB drive.
 - 1. Your USB drive will have a different name depending on the drive and if you have renamed it.
 - 2. If you are not sure which drive is yours, check the drive letter (ex: USB Drive (F:)) while your USB folder is open.
- c. A window will pop up in the bottom right corner of the screen that says “Safe To Remove Hardware.” Once you see this window, you may remove your USB drive.



Saving Large Files to a Zip File

If an error message appears that says the file is too large to transfer to your USB drive, but there is enough space on the drive for your file, follow these steps. This will save your file(s) in a zip file, a compressed file.

For example, you can use a zip file if you have an 8GB USB drive and a 5GB video, but the computer says it cannot save the file because it is too big.

1. Open the location of the video files in File Explorer.
 - a. Either open Video Files on the Desktop or VHS to DVD folder in the Documents Folder.



OR

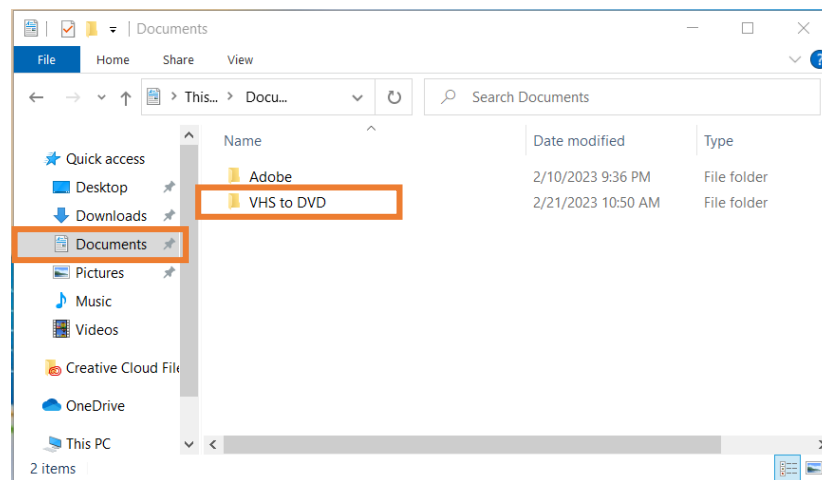

2. Click **Documents** and then **New > New Folder** to create a new folder.

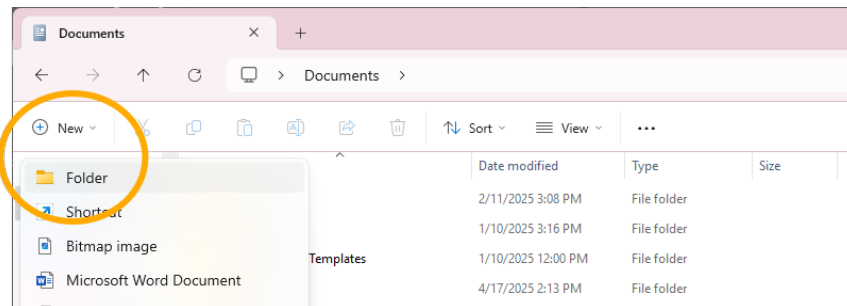

3. Rename the new folder

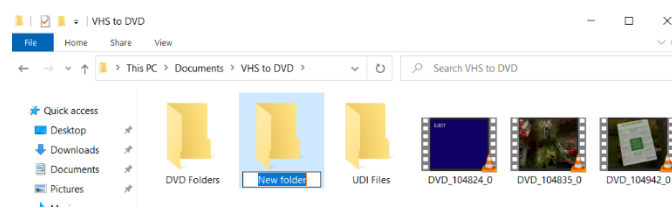

4. Click and drag around the files you want to save to your USB drive. This will highlight them.

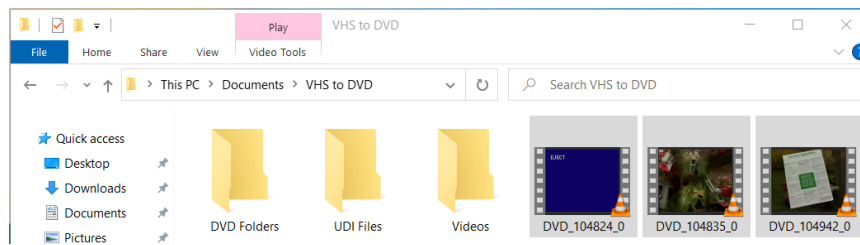

5. Click on the videos and drag them into the new folder.

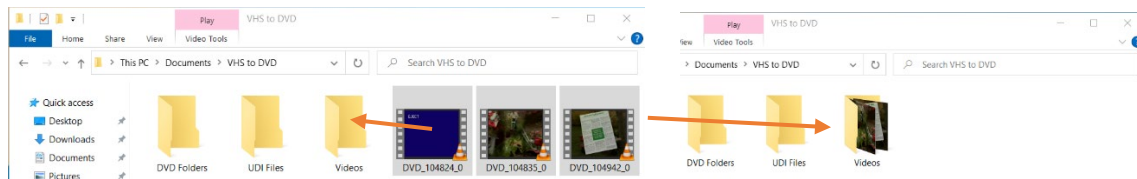

6. Right-click on the folder. A menu will appear.
 - a. Select **Compress to > Zip file**
 - b. Then click **Add to "Videos.zip"**
 - i. **NOTE:** it will not say "Videos" unless that was the name of the folder you created. It will say your folder name.
7. The computer will make a zipped folder.

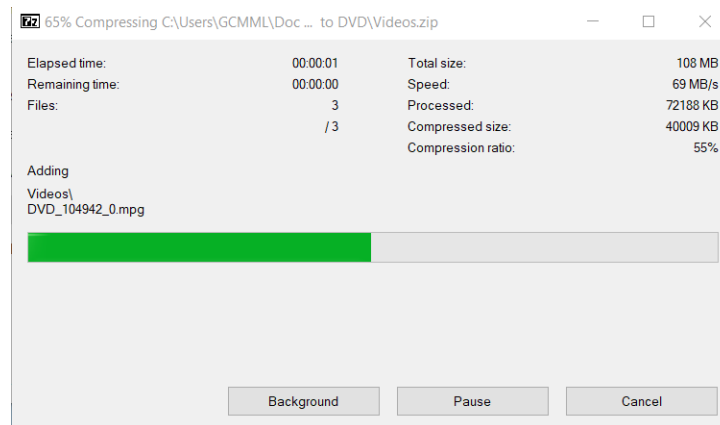

8. Click and drag and new zipped folder to your USB drive.
 - a. A zipped folder has a zipper on it:

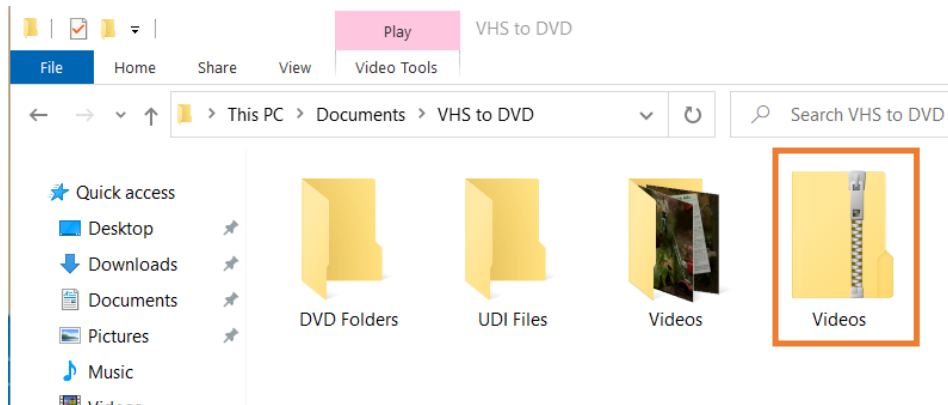

Transferring DVDs and CDs to USB

CD and DVD files are already digital files, but you can transfer or migrate the files to a newer format such as a USB drive. There are multiple ways to transfer the files depending on the disc. Review these options and choose which one works best.

Table of Contents

Click and Drag Files.....	75
Rip a CD or DVD with VLC Media Player.....	77

Click and Drag Files

If the files are saved on the CD or DVD like a flash drive, they can be moved easily to a USB drive. This process is for homemade CDs or DVDs.

1. Plug the USB drive into the computer.
2. Press the button to open the computer CD/DVD drive and place the DVD or CD in the drawer. Close the drawer carefully.



3. Wait as the computer recognizes and reads the disc.
4. Click on File Explorer.



5. Click on the DVD drive.

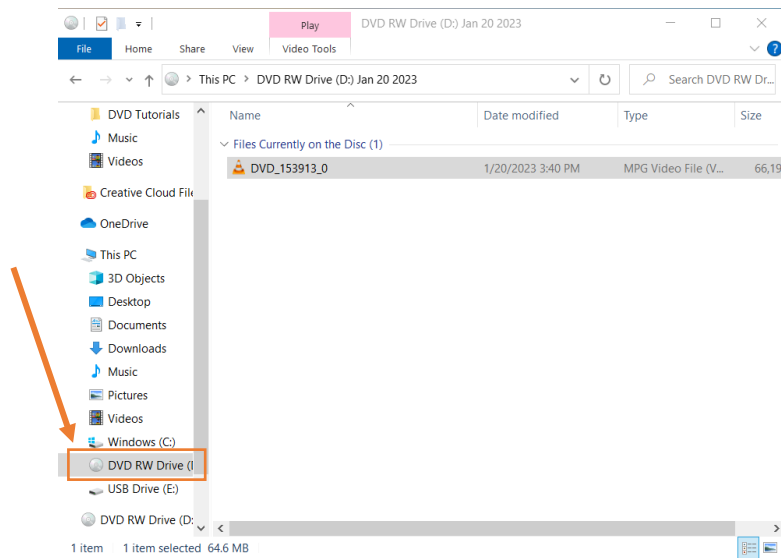

6. Click and drag the files to the USB drive.

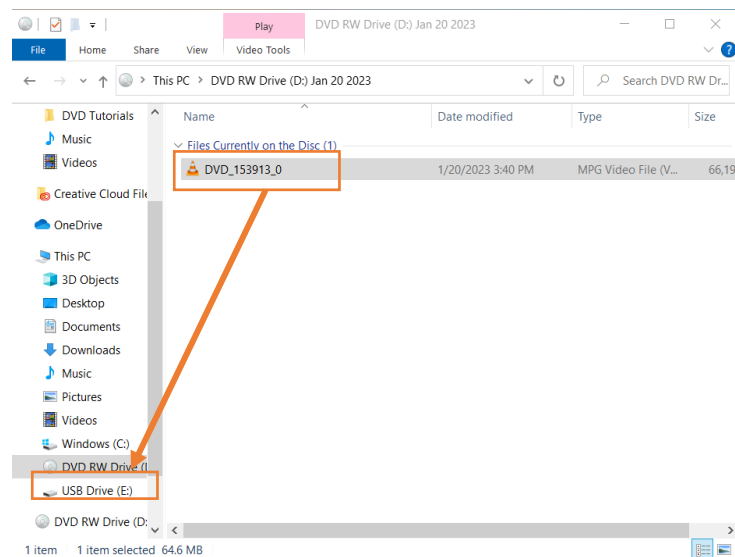

7. Remove the DVD.

- a. Right-click on the DVD or CD drive and choose Eject.
- b. Press the button on the DVD drive and the disc will eject.

8. Add another DVD and repeat steps 2-8 or remove the USB drive when ready.

- a. Right-click on the USB drive and choose Eject.
- b. Click on the carrot in the bottom right corner of the screen and click on the USB icon.

Rip a CD or DVD with VLC Media Player

Transferring files from a protected CD or DVD is known as “ripping.” Protected CDs or DVDs are copyrighted or burned directly onto the disc and therefore do not allow the previous process for transferring the data.

As stated in the user agreement, patrons must follow all applicable intellectual property laws, including all copyright laws. GCPL reserves the right to halt, delete or disallow the creation of items that violate Library policy.

1. Plug in your USB drive.
2. Press the button to open the computer CD/DVD drive and place the DVD in the drawer. Close the drawer carefully.



3. Wait as the computer recognizes and reads the disc.
4. Open **VLC media player**, which has a safety cone as its icon.



5. Click **Media** in the top left corner, and then click **Convert/Save**.

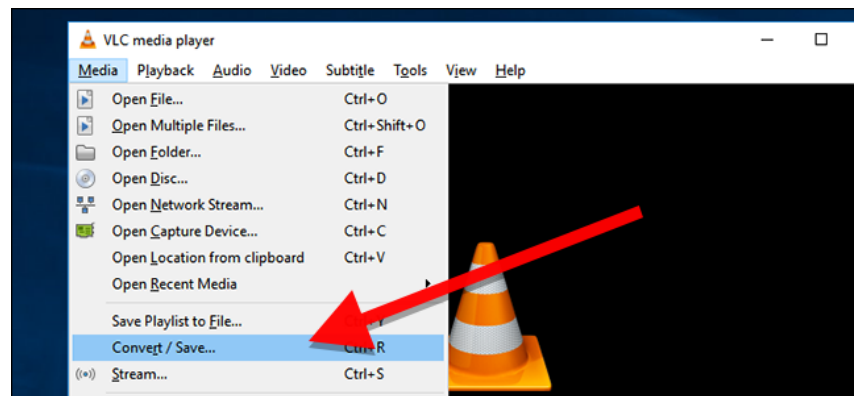

6. The Open Media window will appear. Click the **Disc** tab.
7. Check the DVD box, and make sure that the “Disc Device” field points to the DVD drive. Click the **Convert/Save** button to rip the DVD.

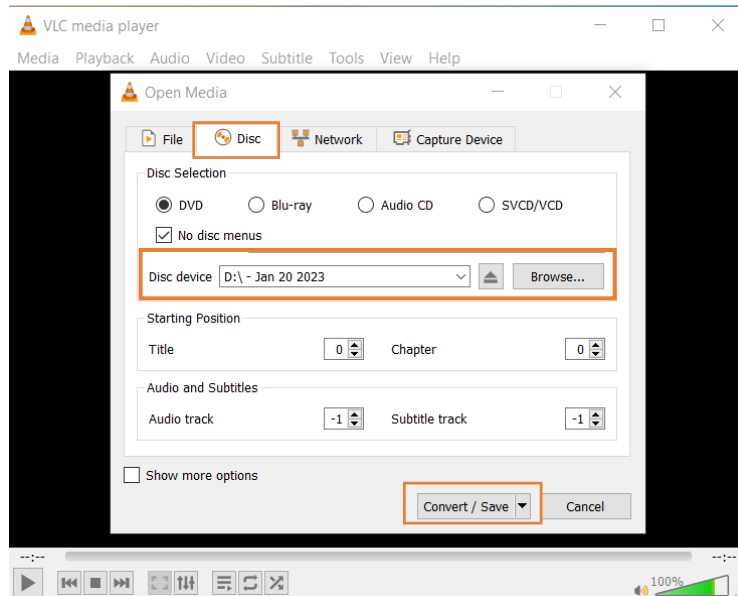

8. Choose where the file will be saved. Click **Browse** and find choose your USB drive.

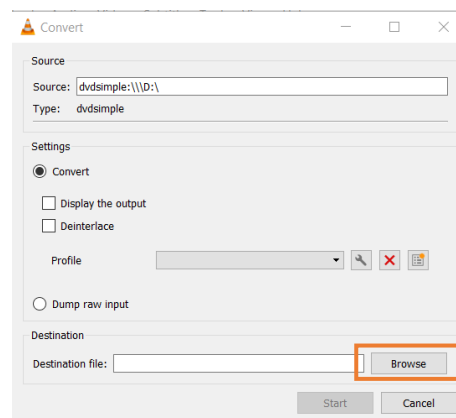

a. Add a title for the new file and click **Save**.

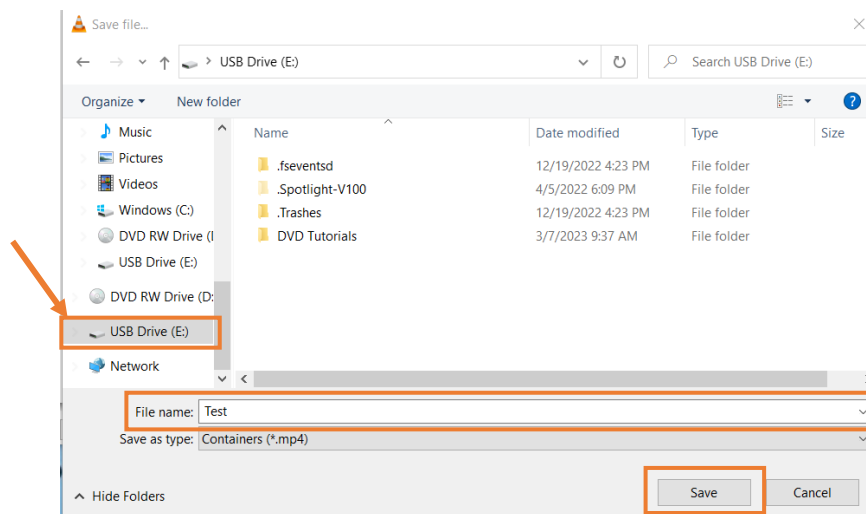

9. Click **Start**.

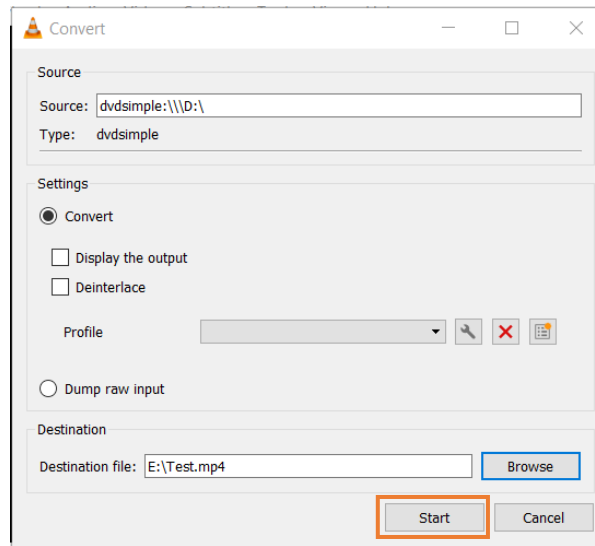

10. VLC media player will convert your file. Wait for it to finish. Once the bar has loaded all the way, it is done.

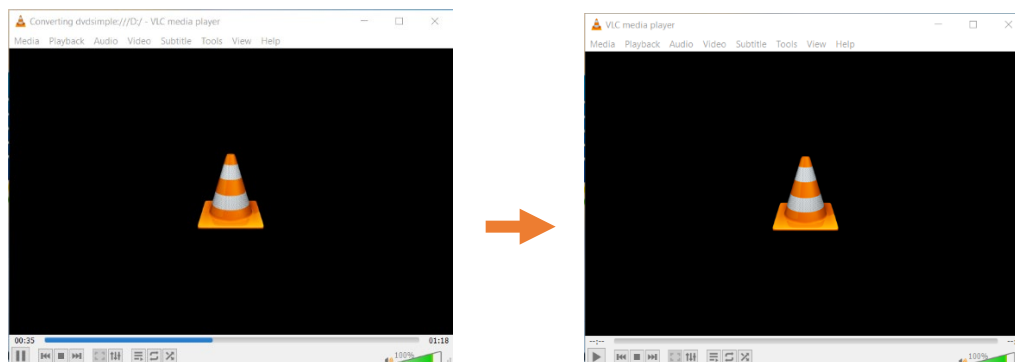

11. Remove the DVD. Either:

- a. Right-click on the CD/DVD drive and choose Eject.
- b. Press the button on the DVD drive and the disc will eject.

12. Add another DVD and repeat steps 5-10 or remove the USB drive when ready.

13. When you are finished, eject your USB drive.

- a. Click on the carrot in the bottom right corner of the screen and click on the USB icon. Click on your USB drive to eject.

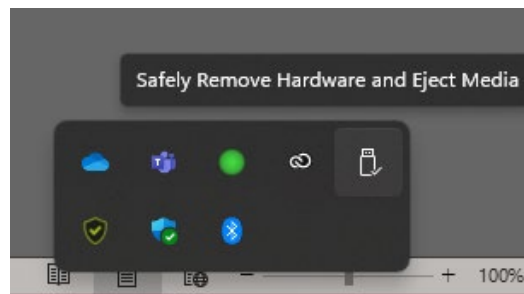
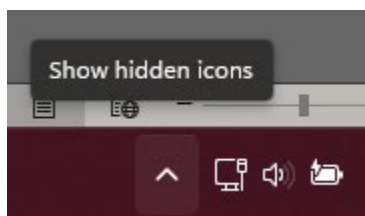

Saving Files to a CD or DVD

Save your files by burning them onto a CD or DVD. These instructions are for burning audio files to a CD, but can also be used to burn a DVD. Once the files are burned, they cannot be further edited. It is highly recommended that you save your files to a USB drive in addition to a CD/DVD to provide a backup.

1. Press the button to open the computer CD/DVD drive and place the DVD in the drawer. Close the drawer carefully.
2. Wait as the computer recognizes and reads the disc.
3. Click on the prompt that appears in the bottom right corner.

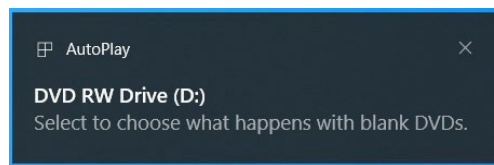

- a. Click **Burn files to disc**.

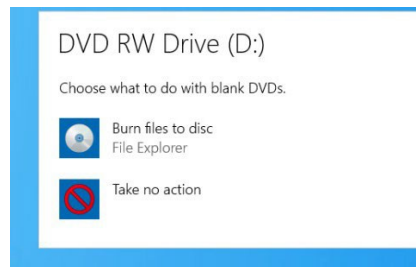

- b. This will open the Burn a Disc window.

4. If the prompt does not appear, click on **File Explorer**:



- a. Double-click on the blank DVD which should have appeared.

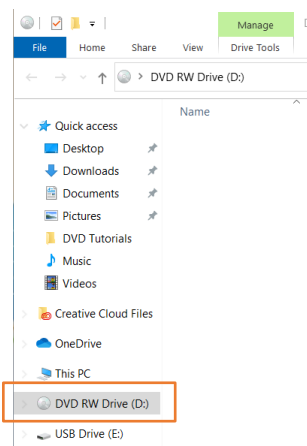

5. This will open the Burn a Disc window.
6. Type a title for your disc (default is the date). This is optional.

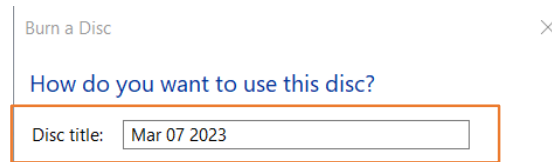

7. Select how you want to use the disc.
 - a. **Like a USB flash drive:** save, edit, and delete files on the disc at anytime.

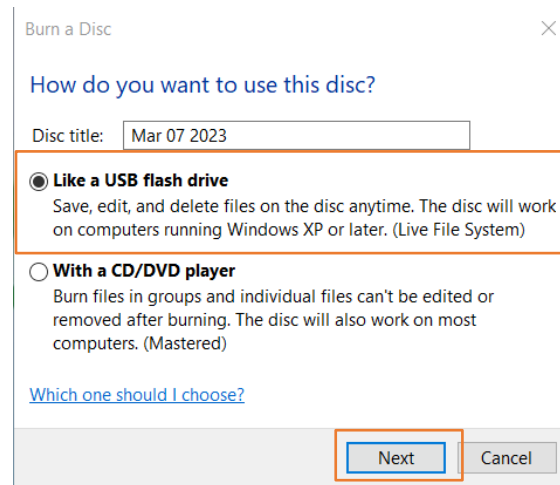

- i. Click **Next**
- ii. Find the files you want saved on the CD or DVD.
 1. These could be on the Desktop in one of the folders, or in the Documents or Videos folder. It depends on the equipment you used to digitize the files.

- iii. Select the files to be added to the disc. Click and drag them to the CD or DVD drive icon on the left.

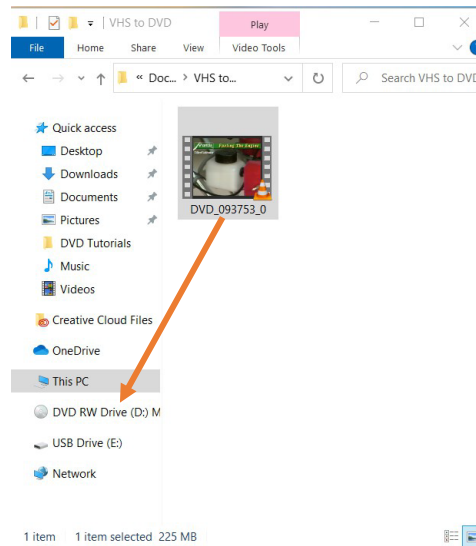

- iv. Click the CD or DVD icon to confirm the files transferred to it.
 - 1. You can now eject the disc.
- b. **With a CD/DVD player:** burn files in groups and individual files can't be edited or removed after burning.

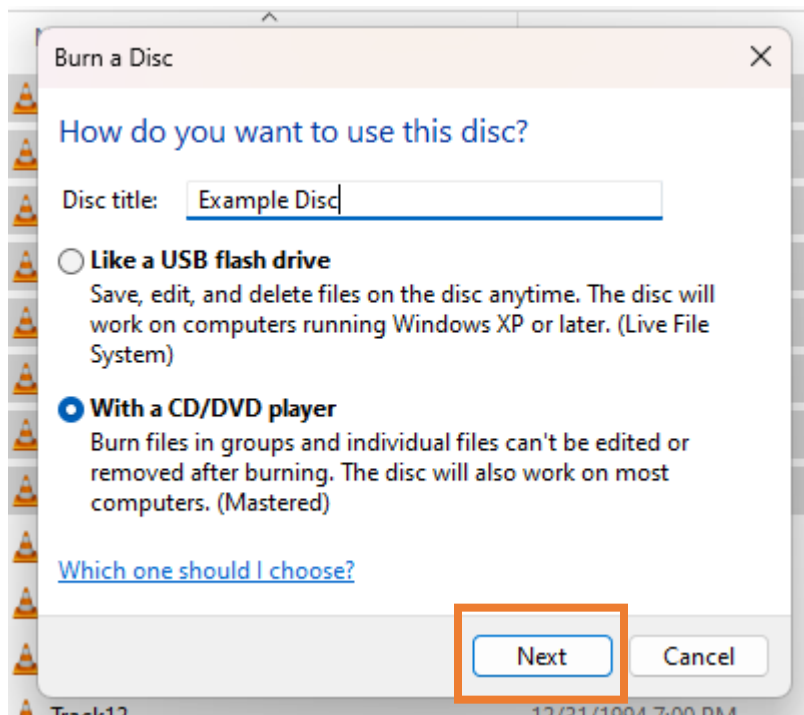

- i. Click **Next** in the Burn a disc window. The disc formatting process begins.

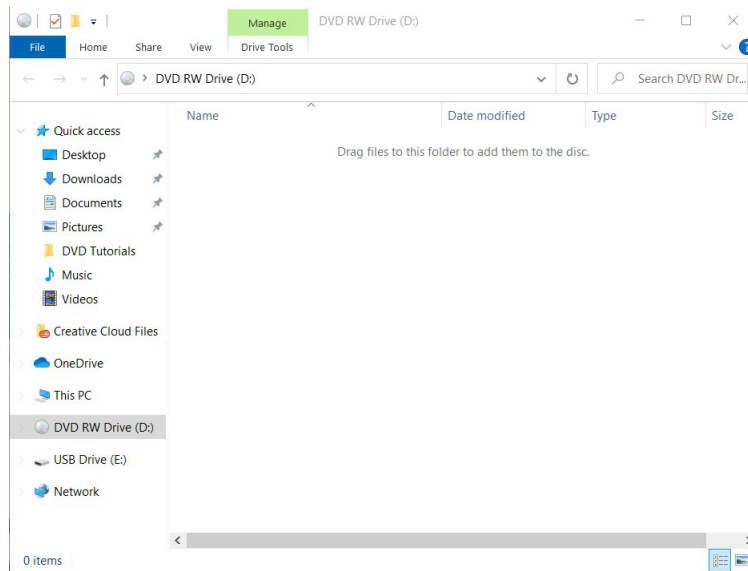

- ii. Find the files you want saved on the CD or DVD.
 1. These could be on the Desktop in one of the folders, or in the Documents or Videos folder. It depends on the equipment you used to digitize the files.
- iii. Select the files to be added to the disc. Click and drag them to the CD or DVD drive icon on the left.

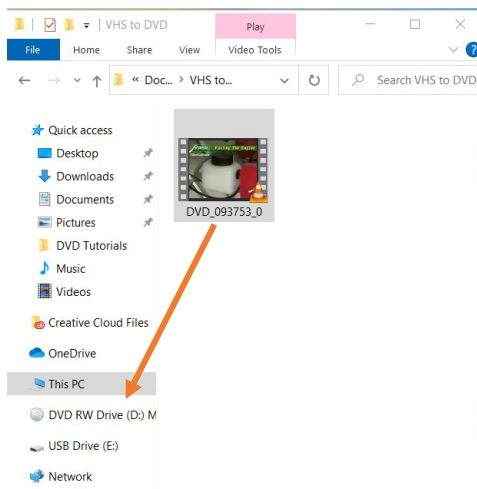

- iv. The files display in a Files Ready to Be Written to the Disc window.

v. Click on three-dots menu (. . .). Select **Finish burning**.

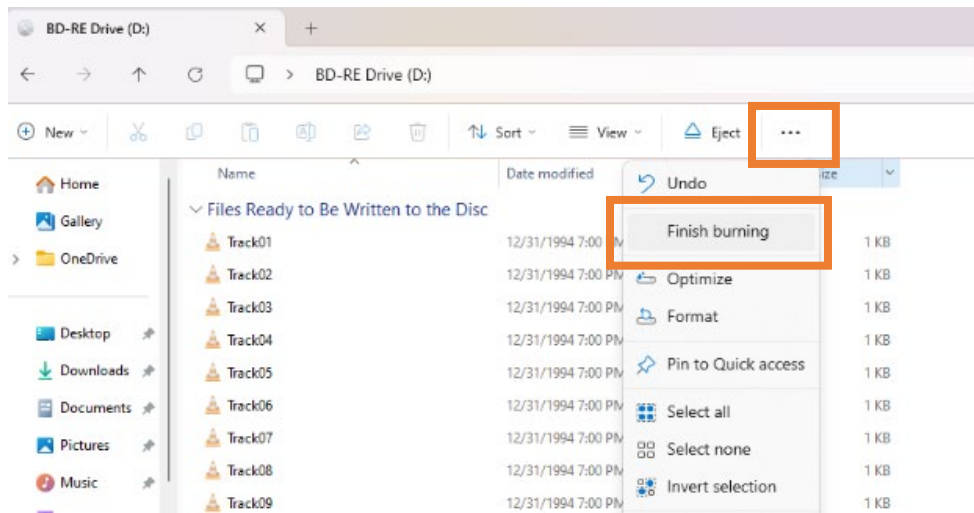

vi. Type a title for your disc if you like (default is the date). Click **Next**.

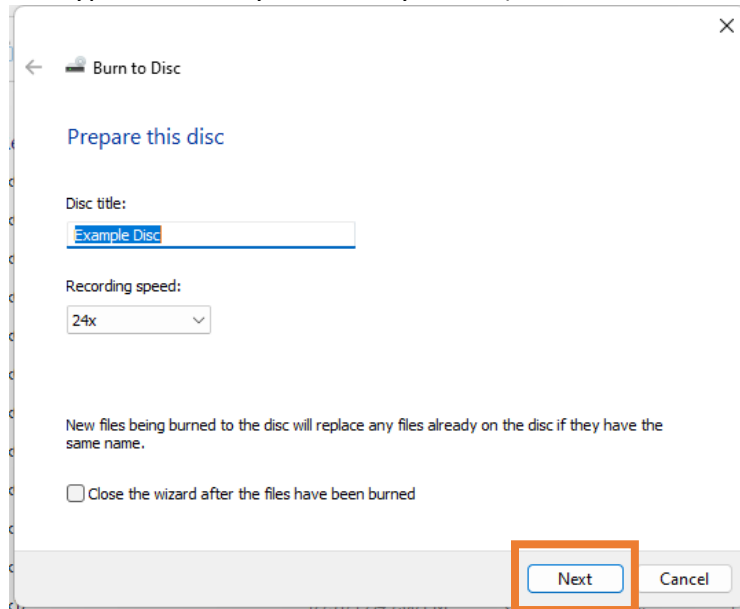

vii. The files will now be burned to the disc.

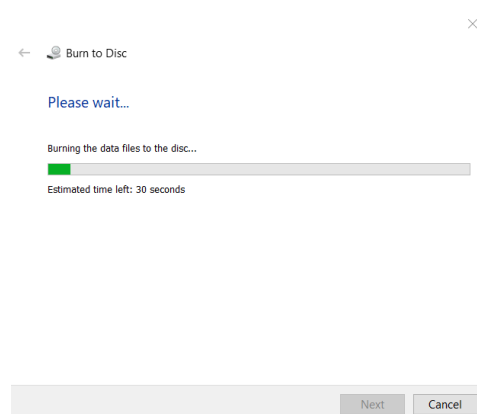

viii. Click **Finish** to close the window. You have successfully burned your files to the disc, and it can be ejected.

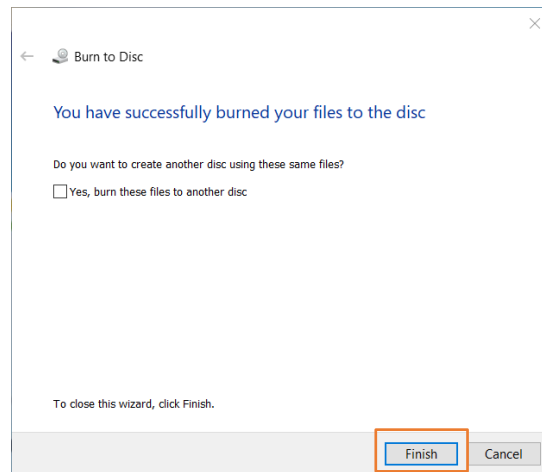



Troubleshooting Guide

General Troubleshooting

Issue	Possible Cause	Solution
Machine not responding	Specific machine not plugged in	Check the power and USB connections. Find the one for the machine you wish to use and make sure it is plugged into the appropriate plug or port. Cables are labeled by machine.
USB drive or memory stick not responding	USB drive not plugged in	Check the USB connections. The USB ports for the Digital Legacy Lab PCs are located on the right side of the screen.
	USB drive not formatted correctly	Confirm that your USB drive has been formatted for Windows PCs. If your USB drive has been formatted to a Mac computer, it may not work properly. Please be sure to bring a PC-compatible USB drive.
File taking too long to save	File size is very large	Option 1: Break up your project into multiple files while digitizing, or use the available editing software to make shorter or smaller files. Option 2: Save as a zip file. Refer to Saving Large Files to a Zip File in the tutorials binder.
	Not a long enough appointment in the Digital Legacy Lab	Reserve multiple times in the Digital Legacy Lab to complete your project. You can always save your work and come back later.
Audio not playing through headphones	Audio output not set correctly	Access the Settings > System > Sound . Under Output , select the device you are using to listen. For your own headphones or the PC speakers, select DLL PC Audio. For the Scarlett Solo

		headphones, select Scarlett Solo Audio.
Media is dirty and will not scan properly	Media needs to be cleaned	One method is to wipe your media with a soft cloth. A microfiber cloth is available in the Digital Legacy Lab bin for this purpose.

8mm and Super8 Film Converter Troubleshooting

Issue	Reason	Solution
My film will not advance through the machine	Film has imperfect splices, film is bent, or broken sprocket holes	Open the flap door while film is stuck, move the problem frames forward. Then close the flap door and continue recording
Some segments are jittery and some are not	Sprocket holes may be damaged from film being played too many times	Try recording and converting the film backwards to use the good edge of the sprocket holes. Then use software to reverse the video
 <p>Imperfect/Bad edge sprocket holes Normal <-----Bad edges-----> </p>		
My film won't go through the machine	Some old film is wider than 8mm at some sections due to loose manufacturing	Place a piece of paper carefully in the track table to keep it wide enough to fit this film
		
The speed of the video is too fast/slow		Edit in software such as Adobe Premiere or VLC Media player
My film is offset.	Film bed needs to be adjusted to center on your film.	4. On the film converter, select Menu.

		<ol style="list-style-type: none"> 5. Navigate to Frame ADJ using the arrow buttons. Press enter. 6. Select X (left/right), Y (up/down), or W (zoom in/out) by pressing the Enter button, then adjust with the arrow buttons.
--	--	---

Auto Feeder Scanner Troubleshooting

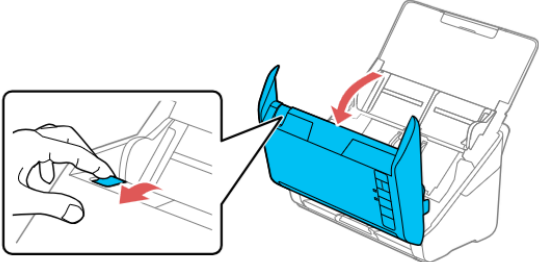
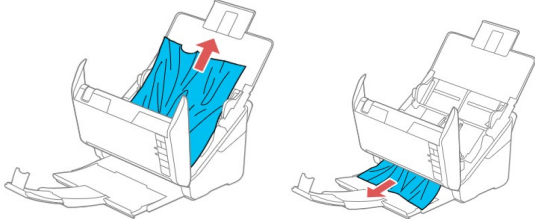
Problem	Solution
<p>Photo or document jam in scanner</p>	<ol style="list-style-type: none"> 1. Turn off scanner 2. Remove docs and photos from input tray 3. Pull down cover open lever to open the scanner cover  <ol style="list-style-type: none"> 4. Gently pull out any jammed originals from inside the scanner and from the output tray  <ol style="list-style-type: none"> 5. Close the scanner cover. Turn scanner on and resume scanning.
<p>Image is too dark</p>	<p>In the Epson FastFoto software, select Settings > Scan Settings. Select the Photo Type best suited for your images.</p> <p>If the image is still dark, try adjusting the Brightness setting. Select Settings > Scanner Settings > Adjustments and set the Brightness.</p>

<p>Image is distorted or blurry</p>	<p>Make sure your original media is not wrinkled or warped, as this will distort the scan.</p> <p>If the image is still distorted,</p> <ol style="list-style-type: none"> 1. In the Epson FastFoto software, select Settings > Scan Settings 2. In Main Settings, be sure to select the correct Image Type for your media 3. In Advanced Settings, select Curled photo correction if your photos are curled.
<p>Scanned image colors do not match original colors</p>	<p>Printed colors never exactly match colors on the computer monitor because printers and monitors use different color systems.</p> <p>If you would still like to adjust the colors in the scanned image:</p> <ol style="list-style-type: none"> 1. In the FastFoto software, select Settings > Scan Settings. Make sure to select the correct Image Type for your media 2. In the FastFoto software, select Enhance to let the program adjust the image resolution. 3. You can also adjust the image resolution using editing software such as Adobe Photoshop.

Cassette and Vinyl Record Troubleshooting

Problem	Cause	Solution
Recording sounds loud and distorted	The gain level is too high	Option 1: Slide the gain slider next to the levels.
Recording is barely audible	The gain level is too low	Option 2: Turn the gain knob on the cassette player.
Cannot hear the recordings once transferred and trying to play them on the computer	Computer audio output not set correctly.	Access the Settings > System > Sound . Under Output , select the device you are using to listen.
While the USB device is connected, can't listen to any music from the computer		
Audacity is not registering any audio recording, but the record is playing.	Audio input not set correctly	Click the Audio Settings dropdown menu. Select Input , then select the device you are using to record.
Recordings are mono instead of stereo	Recording input properties not set to "stereo"	May need to manually specify "stereo." In Audacity :

		<p>Select Audio Setup > Recording Channels > 2 (Stereo)</p> <p>If Audacity is set to “stereo” but recording is still “mono”:</p> <ol style="list-style-type: none"> 1. Go to Settings, then select System, then Sound. Click the Input tab and highlight the Microphone input for the device you are using 2. Click on Properties to bring up the input settings. Click on the Advanced tab and select 2 channel, 16 bit, 44100 Hz (CD quality) in the Default Format pull-down menu. Click Apply to accept the settings.
Vinyl: The sound from the USB device’s audio outputs is distorted or full of static	Line/phono level switch may not be set properly.	Check the line/phono switch on the vinyl record player and make sure it is set to the appropriate level for the inputs connected.

Microphone and Live Audio Troubleshooting

Problem	Cause	Solution
Cannot hear the recordings once saved and trying to play them on the computer	Audacity transport settings or computer audio output not set correctly.	Check the transport settings in Audacity: Select Transport > Transport Options > Enable audible input monitoring
While the microphone is connected, can’t listen to any music from the computer		Confirm PC output is set correctly: Access the Settings , then select System , then select Sound . Under Output , select the device you are using to listen.

Audacity is only registering audio through one ear while I am recording	Microphone audio only accessible via input 2	Refer to Microphone and Live Audio Basics Tutorial step 9 to mix the stereo down into mono.
Audacity is not registering any audio recording, but I am speaking into the microphone/playing music.	Audio input not set correctly	Click the Audio Settings dropdown menu. Select Input . Select Scarlett Solo Converter .
Audacity is not registering any audio recording, and the audio input is set correctly.	Recordings are mono instead of stereo.	<p>Reset settings to “stereo.”</p> <p>In Audacity:</p> <p>Select Audio Setup > Recording Channels > 2 (Stereo)</p> <p>If Audacity is set to “stereo” but recording is still “mono”:</p> <ol style="list-style-type: none"> 1. Go to Settings, then select System, then Sound. Click the Input tab and highlight the Microphone input Scarlett Solo Input. 2. Click on Properties to bring up the input settings. Click on the Advanced tab and select 2 channel, 16 bit, 44100 Hz (CD quality) in the Default Format pull-down menu. Click Apply to accept the settings.

VHS/DVD and Camcorder Tape Converter Troubleshooting

Problem	Cause	Solution
The device is playing but there is no video or audio playing on the PC	The All-in-One converter is not correctly plugged into the device.	Plug each cord into its color-corresponding plug on the device. Make sure that the USB port is plugged into the USB strip.
Cannot hear the recordings once saved and trying to play them on the computer	Computer audio output not set correctly.	Access the Settings > System > Sound . Under Output , select the device you are using to listen.

Audio is playing, but no video is playing on the Honestech software	The Honestech software options are not set correctly.	In Honestech, click Option . Make sure “AV TO USB 2.0” is selected for Video Device. Make sure “AV to USB 2.0” is selected for Audio Device. Select OK.
The AV to USB2.0 option is greyed out in the Honestech software	Computer volume mixer settings not set correctly	Close Honestech. Access the Settings > System > Sound . Under Advanced Options , select Volume Mixer . In the Input device dropdown menu, select AV to USB2.0 . Restart Honestech.
The Hi8/8mm camcorder is playing audio, but no audio is playing on the Honestech software	Camcorder speaker is on.	Close the LCD screen to turn off the camcorder speakers.
The MiniDV camcorder is playing audio at the same time that the Honestech software is, or with a slight lag.	This is normal.	
Camcorder cassette compartment will not open or eject a tape.	The camcorder is not charged.	Make sure that the battery pack is inserted into the camcorder correctly. Connect the charging cable to the camcorder and plug it into the power strip. Be sure to leave the camcorder plugged in while recording to avoid any loss of power.
Camcorder will not turn on.		
Camcorder turns off in the middle of recording.		